



Maruzen

Water Pressure Rice Washer

Water Pressure Rice Washer

4models

Draft Type Water Pressure Rice Washer

3models

All **7** models

You are free from working for troublesome rice washing operation!
Washing rice quickly with easy operation!



General commercial kitchen Appliances & Equipment



MARUZEN Co., Ltd.

April 2018 edition

You are free from working for a troublesome rice washing operation! Washing rice quickly with easy operation!

Water Pressure Rice Washer

MRW-7

List Price : ¥50,000
(tax-excluded)

Rice Washing Ability
7
kg/time



MRW-7 is light and useful

- Compact size of Width 445 x Depth 490. Installation work is unnecessary since it can be used in the sink.
 - It need to be connected with water only when you use it due to easy nose nipple joint.
 - It is easy to carry because of 6kgs.
- ※ Please pay attention to the effective dimension of sink.

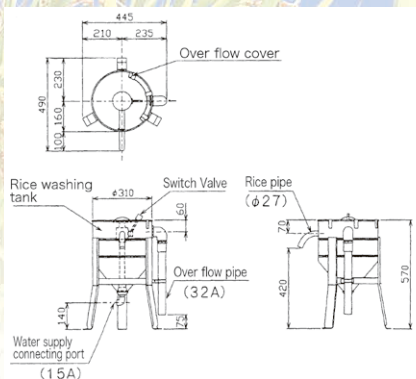

MRW-15

List Price : ¥86,000
(tax-excluded)

Rice Washing Ability
15
kg/time

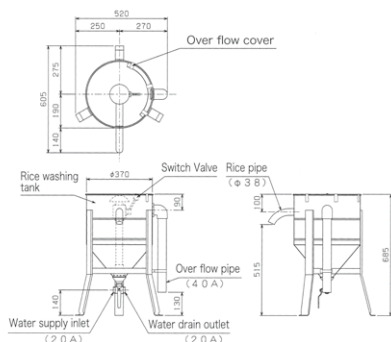

MRW-22

List Price : ¥106,000
(tax-excluded)

Rice Washing Ability
22
kg/time

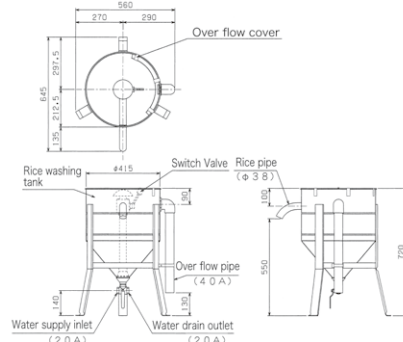

MRW-30

List Price : ¥113,000
(tax-excluded)

Rice Washing Ability
30
kg/time

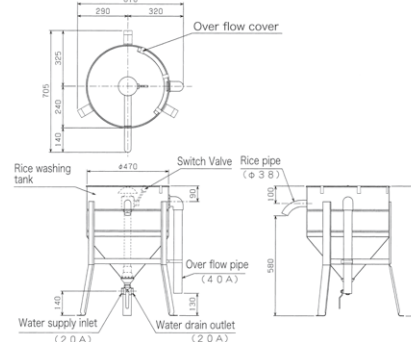

■ Spec. table / Water Pressure Rice Washer

Model	External dimension (mm)			Rice Washing Ability (kg/time)	Operating Water Pressure (kg/cm ²)	Rice washing time (min)	Water supply inlet	Water drain outlet	Weight (kg)
	Width	Depth	Height						
MRW-7	445	490	570	7	0.4~1.0	2~3	15A (Attached 13mm hose nozzle)	Same as Feed-water inlet	6
MRW-15	520	605	685	15	0.8~1.5	2~3	20A	20A	8.5
MRW-22	560	645	720	22	0.8~1.5	2~3	20A	20A	9
MRW-30	610	705	750	30	0.8~1.5	2~3	20A	20A	10

- Water Pressure type washes rice gently.
- Operation is easy, so anyone can wash rice quickly.
- It is easy to care the body of the machine because it is made from all hygienic stainless.

Draft Type Water Pressure Rice Washer

It is hygienic because height from the floor is over 600mm!

Height from the floor to the basket receiver is between 660mm and 800mm. It is hygienic since the height meets the standard of "Manual of Facilities Hygiene Management for Mass Cooking" and "Standards of Hygiene Management for School Catering".

Space saving & easy to install!!

It can have wider choices of installation place because Rice pipe is designed on space saving at the upper main body. Moreover, it needs only a half space for installation comparing with regular model. Because the drainage can be smaller scale due to reducing of splashing water to the around.

The basket which receives rice is only have to be put on the Basket receiver of the upper main body. It is efficient you can work while standing.



MRW-D14

List Price : ¥120,000
(tax-excluded)

Rice Washing Ability
14
kg/time

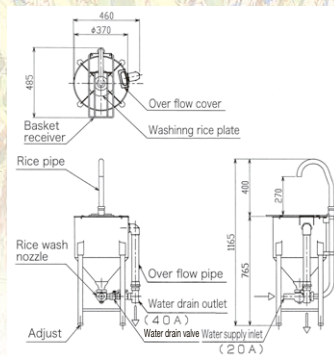

MRW-D7

List Price : ¥100,000
(tax-excluded)

Rice Washing Ability
7
kg/time

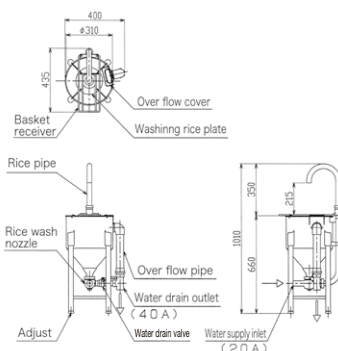

MRW-D28

List Price : ¥150,000
(tax-excluded)

Rice Washing Ability
28
kg/time

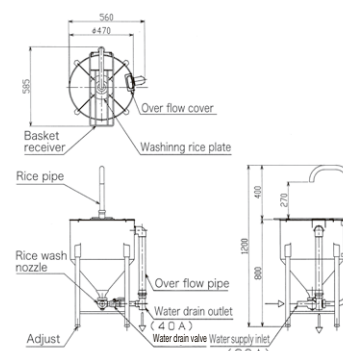

Spec. table / Draft Type Water Pressure Rice Washer

Model	External dimension (mm)			Rice Washing Ability (kg/time)	Operating Water Pressure (kg/cm ²)	Rice washing time (min)	Water supply inlet	Water drain outlet	Weight (kg)
	Width	Depth	Height						
MRW-D7	400	435	660 (1010)	7	0.5~1.2	2~3	20A (Attached 16mm hose nozzle)	40A	11
MRW-D14	460	485	765 (1165)	14	0.5~1.2	2~4	20A (Attached 16mm hose nozzle)	40A	12
MRW-D28	560	585	800 (1200)	28	0.5~1.2	2~5	20A (Attached 16mm hose nozzle)	40A	14

Safety Precautions

- Please receive "instruction manual" when purchasing equipments, and read carefully the "instruction manual" before using it. Please do not use for a purpose not described in "instruction manual" and for prohibited matter. Further, please do not use for purpose other than the intended use. Otherwise misuse will cause accidents such as carbon monoxide poisoning, fire and burn and will be cause of breakdown.
- Please do not use gaseous species and a power source (phase, voltage, frequency) not displayed in the main body. Otherwise, it will cause accident and will be cause of breakdown.
- Please do not disassemble or modify the equipment by all means. Otherwise, it will cause the accident or breakdown.

Precaution for Installation

- Equipment installing/moving work and ancillary facility works for such as gas, electricity, steam and water should be in accordance with Fire Service Act, Fire prevention ordinance and "Standards and Practical Guidelines for installing gas equipment". And please thoroughly read the manual instruction or working instruction and ask your dealer that you purchased or a specialized facility management company to properly install your product onto a safety place.
- In a place where a thermal equipment and an exhaust duct with an exhaust hood are installed, please use non-combustible materials such as concrete, brick and mortar for finishing and grounding (inside part of finishing) of equipment body's surrounding area and the upper surrounding area (backward, lateral, upper, floor face and ceiling)
- Where the finishing and grounding of the equipment body's surrounding area and the upper surrounding area are made by other material than non-combustible material when installing a thermal equipment and the exhaust duct with an exhaust hood, please install the equipment with offset distance specified for each equipment. Otherwise, it will cause a fire.
Please carefully read "instruction manual" and "working instruction" for non-combustible material and installation standards.
- Be sure to install a heat-resistant/non-combustible exhaust duct with an exhaust hood upon the thermal equipment. As to equipments for generating oil smoke and steam, please install an exhaust duct with an exhaust hood which includes grease removing device. An exhaust fan of an exhaust duct should be operated while an air supply opening is absolutely necessary to be provided at an equipment-installed place.
- Please be sure so as not to extend an exhaust stack of the equipment using gas. Otherwise, it will lead to insufficient performance of equipment, accidents such as carbon monoxide poisoning, fire and burn, or breakdown.
- As to power source of equipment using electricity, please use a correctly-wired dedicated plug or a breaker separately. Be sure to install an earth for the prevention of electric shock (Third-class installation work)
- Please install not to be directly affected by the wind. Otherwise, it may cause insufficient performance or an accident such as fire by the flow of wind from an air conditioner.

CAUTION

- Please carry out adequate ventilation, i.e. by turning an exhaust fan when using the thermal equipment.
It must be noted that insufficient ventilation will cause accident such as carbon monoxide poisoning due to incomplete combustion.
- Please do not leave the device when using because it is dangerous.
Be sure to extinguish fire, close the gas main and turn off the power switch when you leave out from the equipment and do not use the equipment. Otherwise, it can cause a fire due to abnormal overheating.
- There is a possibility of causing fire if oil debris and dirt are accumulated too much at the equipment body's surrounding area, a gravy tray/waste oil receiver and a water tray. Please keep it clean.
- Please do not touch any part other than an operation unit because the equipment body and the surrounding part become hot during in use and soon after that. And please keep away your hand and face from the exhaust port. Or you may get burned.
- Do not apply water to equipment body and do not wash the whole part with water. Otherwise, it will cause the malfunction of equipment.
- If an emergency happens such as an earthquake, fire and gas leakage, please stop the usage of equipment and turn off the gas main.
- Please do not put any combustibles or flammables such as a spray, gasoline, benzene, etc upon the equipment and the surrounding area. It may cause fire.
- Please sufficiently consult with a specialized physician when a medical electronic device user such as a pacemaker will use an electromagnetic equipment.
- Products listed herein are for commercial purpose. For domestic use, be sure to consult with a dealer that you purchased or a specialized facility management company and properly install the equipment in accordance with prescribed installation standards.

- The visual appearance and specification of products listed on this catalog may partly be altered due to quality improvement without notice.
- The price in this catalogue may not be the latest one.

Costs for delivery, installation and withdrawal of old model are not included in this price.

General commercial kitchen Appliances & Equipment



MARUZEN Co., Ltd.

Listed on the second section of the Tokyo Stock Exchange (TSE)

<http://www.maruzen-kitchen.co.jp/>

Overseas Division

2-19-18 Negishi, Taito-ku, Tokyo, Japan
Tel: 81-3-5603-7722 Fax: 81-3-5603-7728

Taiwan Maruzen Co., Ltd.

FL.12-3, No.202, Sec.2, Yen-ping North Rd., Taipei, Taiwan, R.O.C.
Tel: 886-2-2550-1355 Fax: 886-2-2550-1399

Maruzen (Thailand) Co., Ltd.

Room 184/193 Floor29-C3 Forum Tower Rachadaphisek Rd. Huai Khwang, Bangkok 10310 Thailand
Tel: 66-2-645-4242 Fax: 66-2-645-4241

contact

For professional use