



Maruzen

Fryer

Model Change

**The model of Gas Fryer
<Excellent Series> is
changed!**

Gas fryer <Suzuchu> 14 models	P1
Gas fryer <Suzuchu> Lower Oil Amount type 4 models	P5
Gas fryer <Standard Series> 11 models	P7
Gas fryer <Excellent Series> 16 models	P11
Gas fryer<Suzuchu> for Delicatessen 4 models	P16
Electric fryer 18 models	P18
Electric auto lift fryer 3 models	P23
Electric fryer for Delicatessen 36 models	P24
Electric tempura fryer 2 models	P33
Electric double auto-lift fryer 3 models	P35
Oil filter 3 models	P37
Doughnut fryer system 4 models	P39
IH tabletop fryer 2 models	P41
IH tabletop auto lift fryer 2 models	P42
IH round shaped fryer 1 model	P43
IH fryer 7 models	P45
IH auto lift fryer 4 models	P47
Electric continuous automatic fryer <small> 8 models	P49
Gas tabletop apron type conveyor fryer 2 models	P51
Gas continuous automatic fryer 8 models	P53



February 2019 edition

All 152 models line-up for gas, electricity and IH with small/large size!

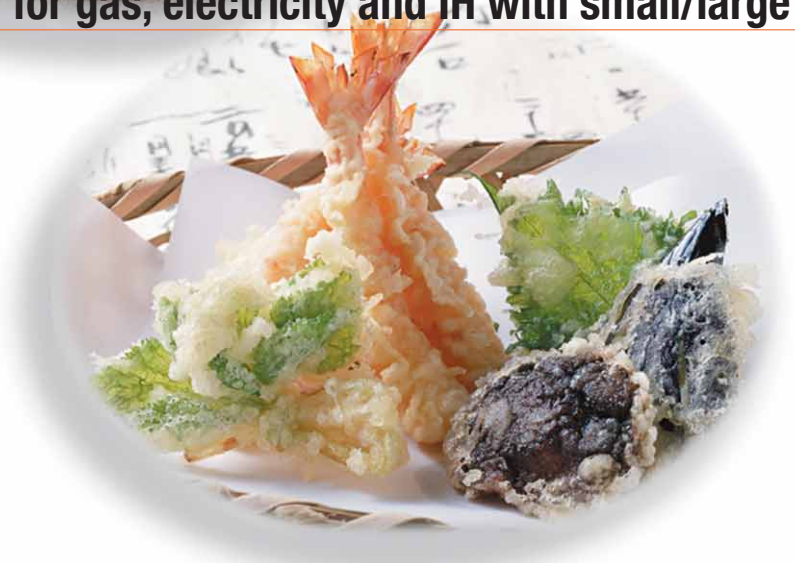

General commercial kitchen Appliances & Equipment



MARUZEN Co., Ltd.



涼しい厨房®

Gas Fryer <Suzuchu>



Improvement on Kitchen environment by suppressing heat from main body.

- Whole oil tank is covered with heat insulator and air heat-insulation layer is provided around the oil tank. This allows the optimized air flow inside the device to take the heat of the body and finally to suppress the radiant heat from the device and reduce the surface temperature rise.
- Removable heat protector is provided at front rail which is easy to access for cooker during cooking. This protector reduces the radiant heat and enhances safety when touching the front rail.



Exhaust stack (right) and heat protector (left). Arrow shows the airflow reducing the heat from the body.



涼厨 (Suzuchu)

"Suzuchu equipment"

is the certified gas appliances that are designed to resist heating up room temperature by exhausting intensively and insulating hot part to lower the radiant heat on the surface of equipment. Therefore, the temperature is kept low so you can touch and convert the work place much more comfortable and safer. ("Suzuchu" is a trademark and 「涼厨」 is the registered trademark of Osaka Gas.)

Large hole heat pipe with excellent thermal efficiency.

Special-circulated heating method by large hole heat pipe realizes excellent thermal efficiency (in-house Product Comparison). Moreover, there is no waste to energy by heating the upper layer only of oil tank for cooking. It is energy saving. Additionally, oil temperature can be heated faster with possibility of speedy service even during peak time. (Except for table top type)

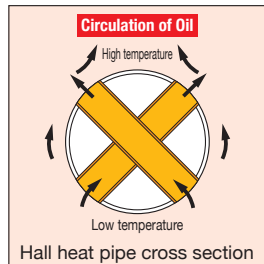

Oil Circulation Prevents Oxidization for Good Frying.

Oil inside the tank circulates at all times to prevent uneven heating and oxidization. Fried scraps sink to the lower temperature area so it is possible to always cook in the clean area at a proper temperature.

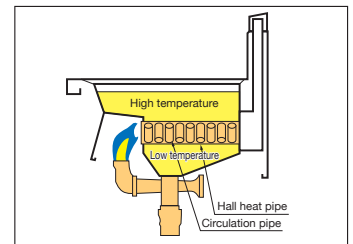

Accurate Oil Temperature Control and Reliable Auto-ignition.

The thermostat keeps the oil temperature at the proper temperature within 160°C to 220°C. Ignition is initiated through a quick and reliable piezoelectric auto-ignition method.

Low-temperature type is also available!

Low-temperature type that can be set oil temperature between 140°C to 180°C is also available (The price is the same). Please contact us for more details.

- *「-LO」is added at the end of the model.
- * This is a built-to-order product.

Easy-to-Clean Oil Tank Construction.

It is easy to clean because the bottom of the oil tank can be easily reached with a hand. Turn the oil drain cock to drain oil into the waste oil tank with casters.



Preventing Pilot Burner Clogging.

The pilot burner is equipped with a nozzle cleaning mechanism that allows you to easily clean clogged nozzles. (Except for table top type)



Numerous Functions to prevent unexpected Troubles.

The temperature control dial and gas cock are covered to prevent ingress of accidentally splattered oil. The exhaust stack cover prevents small objects from falling down. There are also a flame rod and an overheat protection device.



It is easier to clean and install the gas pipes.

We made a space which is 150mm higher than the ground. That makes the cleaning and installing the gas pipes easier. (Except table top type)



The model of depth 450mm type is also changed to the same specification.



Products with this mark, has passed the type inspection of the Japan Gas Appliances Inspection Association. (LP gas, 13A)

Gas fryer <Cool kitchen Series> is offered with a type that conforms to the specification of the description of the Minister of Land, Infrastructure and Transport Secretariat Government Buildings Department supervision "public building construction standard specifications" (machine knitting equipment work).



MGF-C13K

List Price : ¥162,000 (tax-excluded)

Oil amount 13ℓ

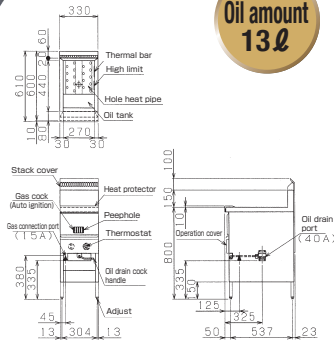

MGF-C18K

List Price : ¥178,000 (tax-excluded)

Oil amount 18ℓ

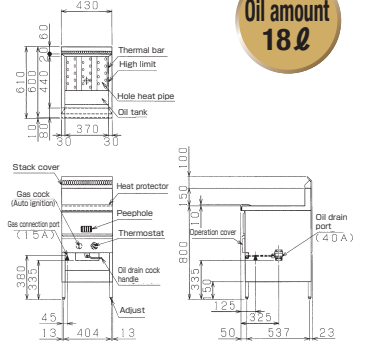

MGF-C23K

List Price : ¥184,000 (tax-excluded)

Oil amount 23ℓ

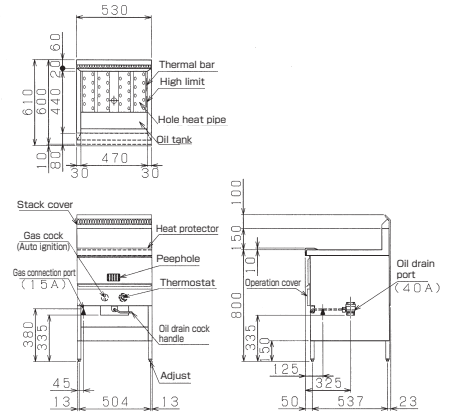

MGF-C30K

List Price : ¥240,000 (tax-excluded)

Oil amount 30ℓ

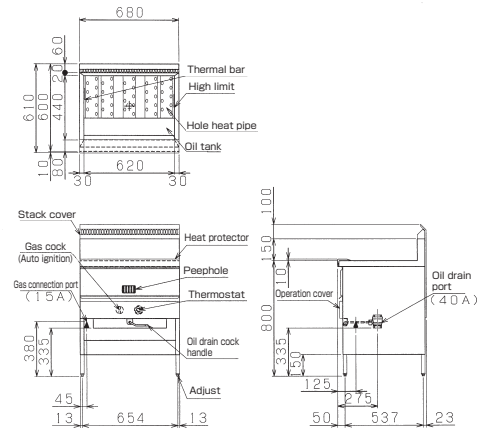

MGF-C40K

List Price : ¥268,000 (tax-excluded)

Oil amount 40ℓ

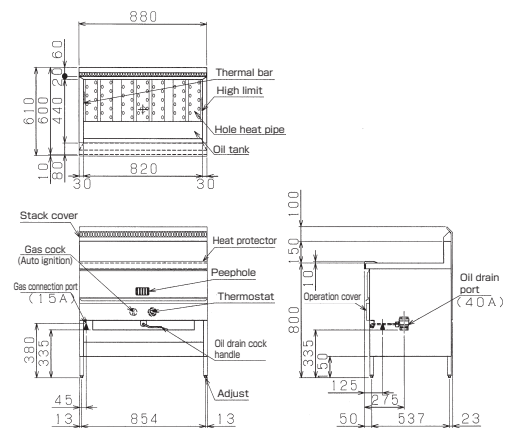

MGF-C13WK

List Price : ¥260,000 (tax-excluded)

Oil amount 13ℓ×2

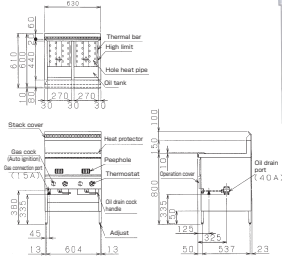

MGF-C18WK

List Price : ¥291,000 (tax-excluded)

Oil amount 18ℓ×2

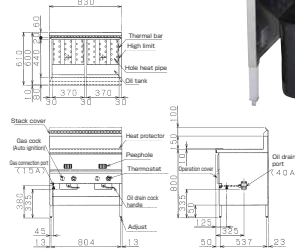

MGF-C23WK

List Price : ¥301,000 (tax-excluded)

Oil amount 23ℓ×2

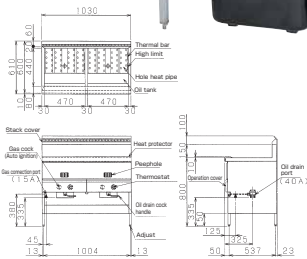

MGF-C30WK

List Price : ¥461,000 (tax-excluded)

Oil amount 30ℓ×2

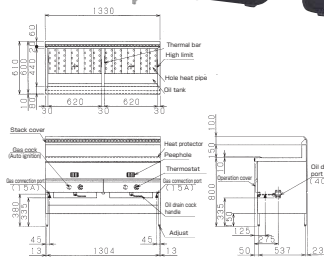

Regular type -1-tank

Depth 450mm type.

MGF-CM10K

List Price : ¥158,000 (tax-excluded)

Model Change

Oil amount 10ℓ

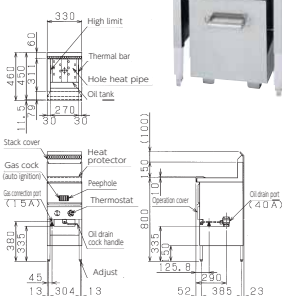

MGF-CM13K

List Price : ¥174,000 (tax-excluded)

Model Change

Oil amount 13ℓ

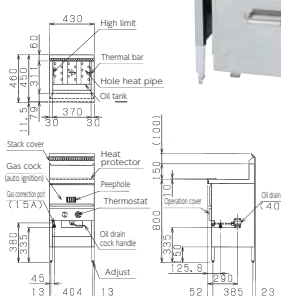

MGF-CM18K

List Price : ¥180,000 (tax-excluded)

Model Change

Oil amount 18ℓ

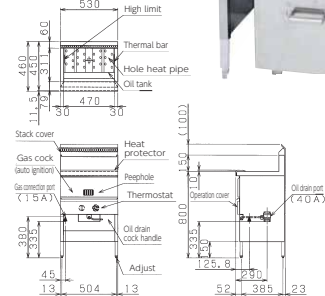

MGF-C13FK

List Price : ¥205,000 (tax-excluded)

Oil amount 18ℓ

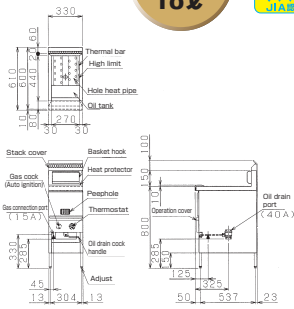

MGF-C12TJ

List Price : ¥135,000 (tax-excluded)

Easy to install thanks to small size.

Oil amount 12ℓ

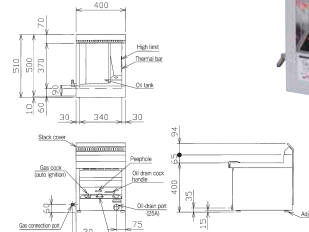

Gas fryer <Suzuchu> Specifications Table

Model	External dimension (mm)				Oil amount (ℓ)	Gas consumption		Gas connection		Weight (kg)	Accessories														
	Width	Depth	Height	Height back		Town gas	LP gas	Town gas	LP gas		Heat protector	Oil tank, large	Oil tank, small	Oil screen (L)	Oil screen (S)	Oil drain plate	Oil drain net	Partition net	Skimming net	Cover	Sliding plate	Frier foot basket	Front basket	Basket hook	
Regular type	MGF-C13K	330	600	800	150	13	6.40kW(5,500kcal/h)	6.40kW(0.46kg/h)	15A	15A	35.5	1													
	MGF-C18K	430	600	800	150	18	8.72kW(7,500kcal/h)	8.72kW(0.62kg/h)	15A	15A	37	1	1												
	MGF-C23K	530	600	800	150	23	11.6kW(10,000kcal/h)	11.6kW(0.83kg/h)	15A	15A	44	1	1												
	MGF-C30K	680	600	800	150	30	14.5kW(12,500kcal/h)	14.5kW(1.04kg/h)	15A	15A	54	1		2											
	MGF-C40K	880	600	800	150	40	17.4kW(15,000kcal/h)	17.4kW(1.24kg/h)	15A	15A	60	1	1	1	1	1	1	1	1	1	1	1	1	1	
	MGF-C13WK	630	600	800	150	13×2	12.8kW(11,000kcal/h)	12.8kW(0.91kg/h)	15A	15A	55.5	1		2											
	MGF-C18WK	830	600	800	150	18×2	17.4kW(15,000kcal/h)	17.4kW(1.24kg/h)	15A	15A	69	1	2												
	MGF-C23WK	1,030	600	800	150	23×2	23.3kW(20,000kcal/h)	23.3kW(1.66kg/h)	15A	15A	78	1	2	2											
	MGF-C30WK	1,330	600	800	150	30×2	29.1kW(25,000kcal/h)	29.1kW(2.08kg/h)	15A×2	15A×2	102	1	2	1	2	1	1	1	2	2	2	2	2	2	2
	MGF-CM10K	330	450	800	150	10	6.40kW(5,500kcal/h)	6.40kW(0.46kg/h)	15A	15A	36	1		1											
MGF-CM13K	430	450	800	150	13	8.72kW(7,500kcal/h)	8.72kW(0.62kg/h)	15A	15A	41	1		1	1											
MGF-CM18K	530	450	800	150	18	11.6kW(10,000kcal/h)	11.6kW(0.83kg/h)	15A	15A	47	1	1		1	1										
Fast Food type	MGF-C13FK	330	600	800	150	18	6.40kW(5,500kcal/h)	6.40kW(0.46kg/h)	15A	15A	35.5	1		1								2		1	
Table Top type	MGF-C12TJ	400	500	400	65	12	6.40kW(5,500kcal/h)	5.81kW(0.42kg/h)	1.3mm rubber tube mouth	9.5mm rubber tube mouth	28	1												1	

Gas fryer <Suzuchu> Accesories

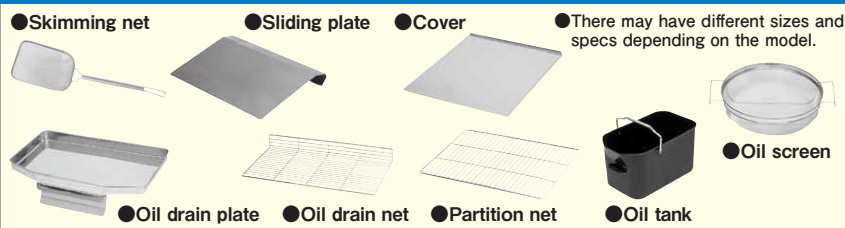

Option



Gas fryer <Suzuchu> Cooking ability

Model	Foodstuff	Croquette(raw 50g) (pcs / hour)	Deep-fried breaded pork(pcs / hour)	Horse mackerel tempura(pcs / hour)	Vegetable tempura (pcs / hour)	French fries (kg / hour)	French fries (kg / hour)
MGF-C13K		200~250	150~200	250~350	150~400	10	7
MGF-C18K		250~350	200~250	350~450	200~500	15	10
MGF-C23K		350~450	250~300	450~550	250~600	20	13
MGF-C30K		450~550	300~400	550~700	300~800	27	17
MGF-C40K		600~750	400~500	750~900	400~1,000	37	23
MGF-C13WK		(200~250)×2	(150~200)×2	(250~350)×2	(150~400)×2	10×2	7×2
MGF-C18WK		(250~350)×2	(200~250)×2	(350~450)×2	(200~500)×2	15×2	10×2
MGF-C23WK		(350~450)×2	(250~300)×2	(450~550)×2	(250~600)×2	20×2	13×2
MGF-C30WK		(450~550)×2	(300~400)×2	(550~700)×2	(300~800)×2	27×2	17×2
MGF-CM10K		150~200	100~150	150~250	100~300	7	5
MGF-CM13K		200~250	150~200	250~350	150~400	10	7
MGF-CM18K		250~350	200~250	350~450	200~500	15	10
MGF-C13FK						15	10
MGF-C12TJ		200~250	150~200	250~350	150~400	10	7

Temperature of oil and cooking time

Name of the food	Proper oil temperature	Time required
Croquette	180°C~200°C	2~3minutes
Deep-fried breaded pork	180°C~190°C	2~4minutes
Fish fry	180°C~190°C	2~4minutes
Vegetable fry	160°C~180°C	1~3minutes
Potato fry	170°C~180°C	2~5minutes
Mixture of vegetables and other ingredients fried in batter	180°C~190°C	1~2minutes
Deep-fried chicken	180°C~190°C	3~6minutes
French fries(frozen)	180°C	4minutes
Donut	160°C~170°C	2~3minutes

Required time will be 30-50% increased in the case of frozen food.



Gas Fryer <Suzuchu> Lower Oil Amount type **MGF**

Reduced the oil amount with special oval-hole heat pipe! You can reduce the cost of oil remaining the cooking capacity!

Reduced oil amount from 8% to 15% remaining cooking capacity!

Hole heat pipe normally takes wide space in an oil tank. After we adapted special oval-hole heat pipe, we succeeded to save the space for the heating zone in an oil tank. Result of that, we could reduce the oil amount from 8% to 15% remaining the cooking zone. Therefore, you can reduce the cost for buying oil and treatment of waste oil.

The secret is...

Special oval-hole heat pipe equipped.

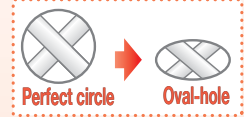

Special oval-hole heat pipe

Oil amount of heating zone Reduced 2ℓ (about 11%)

※In case of MGF-CE16

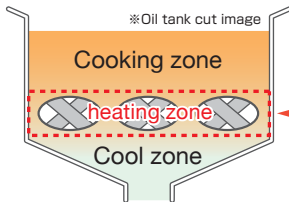

Lower Oil Amount type

Kitchen environment improved by reducing the radiant heat from the main body

We reduced the radiant heat and it is safer when you touch the machine, because we adopted heat insulator and heat protector. Besides, the working environment in the kitchen improved by the chimney structure that there is no diffusion of exhaust gas.



涼厨 (Suzuchu)

"Suzuchu equipment"

is the certified gas appliances that are designed to resist heating up room temperature by exhausting intensively and insulating hot part to lower the radiant heat on the surface of equipment. Therefore, the temperature is kept low so you can touch and convert the work place much more comfortable and safer. ("Suzuchu" is a trademark and 涼厨 is the registered trademark of Osaka Gas.)

Preventing Pilot Burner Clogging.

The pilot burner is equipped with a nozzle cleaning mechanism that allows you to easily clean clogged nozzles.



Oil Circulation Prevents Oxidization for Good Frying.

Oil inside the tank circulates at all times to prevent uneven heating and oxidization. Fried scraps sink to the lower temperature area so it is possible to always cook in the clean area at a proper temperature.

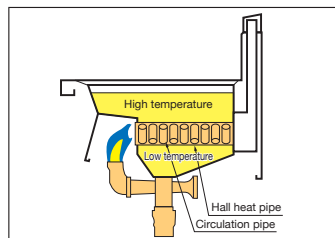

Besides! Save not only cost of oil but also gas!

Because of special-circulated heating method by large hole heat pipe, thermal efficiency is very high, and the starting time is faster. It saves the gas consumption, and very economical. Also, only the upper part of the oil tank is heated due to the middle heating method. That is another reason to make it very economical.

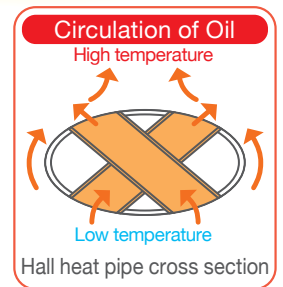

Accurate Oil Temperature Control and Reliable Auto-ignition.

The thermostat keeps the oil temperature at the proper temperature within 160°C to 220°C. Ignition is initiated through a quick and reliable piezoelectric auto-ignition method.

Low-temperature type is also available!

Low-temperature type that can be set oil temperature between 140°C to 180°C is also available (The price is the same). Please contact us for more details.

※「-LO」 is added at the end of the model.

※ This is a built-to-order product.

Numerous Functions to prevent unexpected Troubles.

The temperature control dial and gas cock are covered to prevent ingress of accidentally splattered oil. The exhaust stack cover prevents small objects from falling down. There are also a flame rod and an overheat protection device.

Perfect for floor cleaning

We adopted full open and circle pipe leg for the lower part of the body, therefore it is very easy to clean. Oil protective cover at the bottom of the body protects you from the oil smoke and rebounded oil when you drain.



Products with this mark comply with and are registered by "the JFEA Commercial Kitchen Equipment Standards" of Japan Food Service Equipment Association.

Conformity with Commercial Kitchen Equipment Standards

Gas Fryer <Suzuchu> Lower Oil Amount type

Regular type -1-tank Please choose according to application and space.



MGF-CE12

List Price : ¥162,000
(tax-excluded)

JFEA

Oil amount
12 ℓ

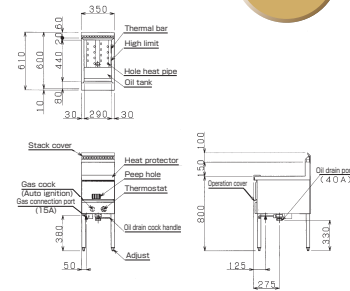

MGF-CE16

List Price : ¥177,000
(tax-excluded)

JFEA

Oil amount
16 ℓ

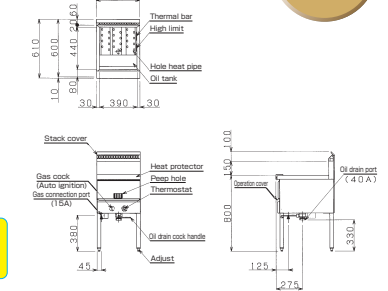

MGF-CE20

List Price : ¥188,000
(tax-excluded)

JFEA

Oil amount
20 ℓ

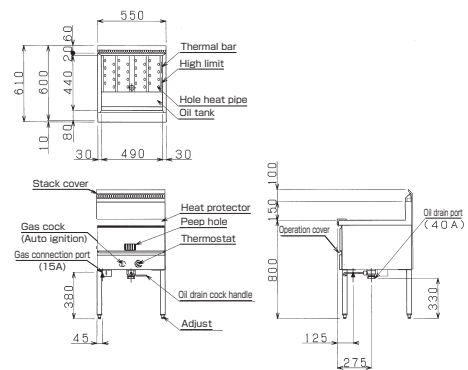

MGF-CE23

List Price : ¥244,000
(tax-excluded)

JFEA

Oil amount
23 ℓ

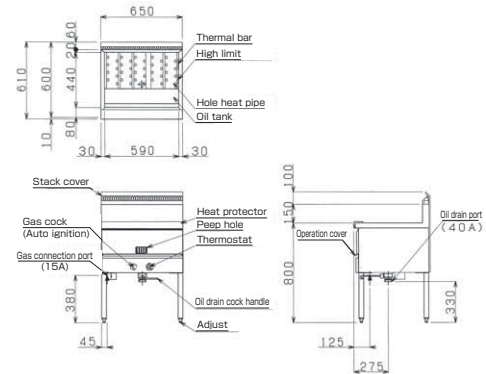

Gas Fryer <Suzuchu> Lower Oil Amount type specification table

Model	External dimension(mm)				Oil amount (ℓ)	Gas consumption		Gas connection		Weight (kg)	Accessories										
	Width	Depth	height	Height back		Town gas	LP gas	Town gas	LP gas		Heat protector	Oil tank, large	Oil tank, small	Oil screen (L)	Oil screen (S)	Oil drain plate	Oil drain net	Partition net	Cover	Skimming net	Sliding plate
MGF-CE12	350	600	800	150	12	6.40kW(5,500kcal)	6.40kW(0.46kg/h)	15A	15A	41.0	1										
MGF-CE16	450	600	800	150	16	8.72kW(7,500kcal)	8.72kW(0.62kg/h)	15A	15A	46.5	1	1									
MGF-CE20	550	600	800	150	20	11.6kW(10,000kcal)	11.6kW(0.83kg/h)	15A	15A	54.0	1	1									
MGF-CE23	650	600	800	150	23	14.5kW(12,500kcal)	14.5kW(1.04kg/h)	15A	15A	64.0	1	1									

Gas Fryer <Suzuchu> Lower Oil Amount type accessories

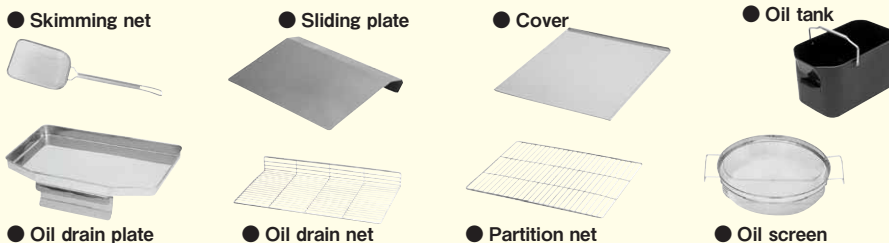

Option

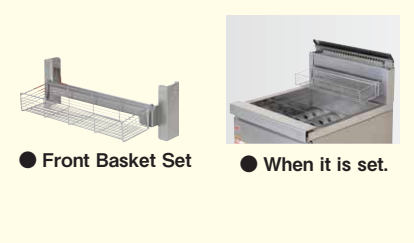

Excellent thermal efficiency and economic efficiency. Longtime seller with excellent cost performance.

Large hole heat pipe with excellent thermal efficiency.

Special-circulated heating method by large hole heat pipe realizes excellent thermal efficiency (in-house Product Comparison). Moreover, there is no waste of energy by heating the upper layer only of oil tank for cooking. It is energy saving. Additionally, oil temperature can be heated faster with possibility of speedy service even during peak time. (Except for table top type)

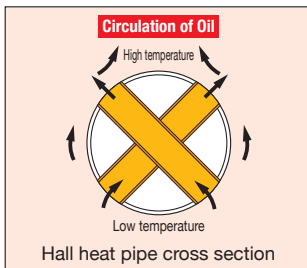

Easy-to-Clean Oil Tank Construction.

It is easy to clean because the bottom of the oil tank can be easily reached with a hand. Turn the oil drain cock to drain oil into the waste oil tank with casters.



Oil Circulation Prevents Oxidization for Good Frying.

Oil inside the tank circulates at all times to prevent uneven heating and oxidization. Fried scraps sink to the lower temperature area so it is possible to always cook in the clean area at a proper temperature.

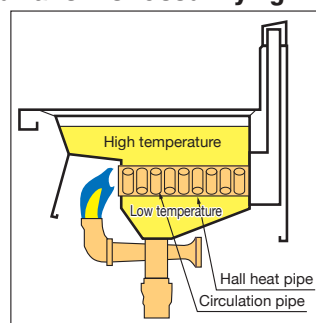

Accurate Oil Temperature Control and Reliable Auto-ignition.

The thermostat keeps the oil temperature at the proper temperature within 160°C to 220°C. Ignition is initiated through a quick and reliable piezoelectric auto-ignition method.



Low-temperature type is also available!

Low-temperature type that can be set oil temperature between 140°C to 180°C is also available (The price is the same). Please contact us for more details.

- *「-LO」is added at the end of the model.
- * This is a built-to-order product.

Numerous Functions to prevent unexpected Troubles.

The temperature control dial and gas cock are covered to prevent ingress of accidentally splattered oil. The exhaust stack cover prevents small objects from falling down. There are also a flame rod and an overheat protection device.



Preventing pilot burner clogging.

The pilot burner is equipped with a nozzle cleaning mechanism that allows you to easily clean clogged nozzles. (Except for table top type)



It is easier to clean and install the gas pipes.

We made a space which is 150mm higher than the ground. That makes the cleaning and installing the gas pipes easier. (Except table top type)



Gas fryer <Standard Series> is offered with a type that conforms to the specification of the description of the Minister of Land, Infrastructure and Transport Secretariat Government Buildings Department supervision "public building construction standard specifications" (machine knitting equipment work).

MGF-13K

List Price : ¥161,000
(tax-excluded)

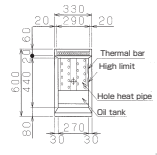

Oil amount
13ℓ

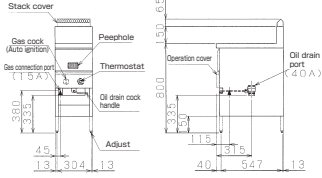

MGF-18K

List Price : ¥177,000
(tax-excluded)

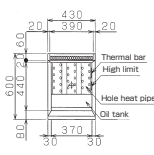

Oil amount
18ℓ

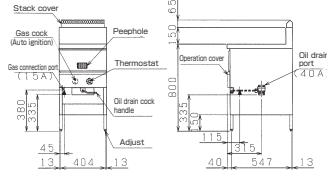

MGF-23K

List Price : ¥183,000
(tax-excluded)

Oil amount
23ℓ

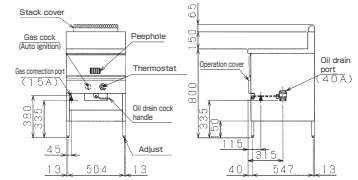
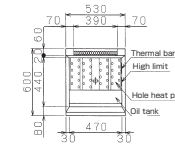

MGF-30K

List Price : ¥239,000
(tax-excluded)

Oil amount
30ℓ

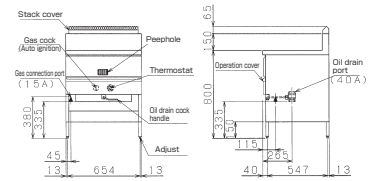
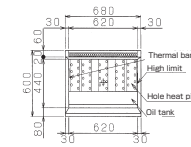

MGF-40K

List Price : ¥267,000
(tax-excluded)

Oil amount
40ℓ

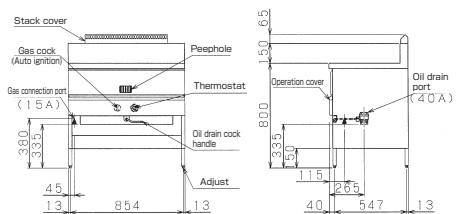
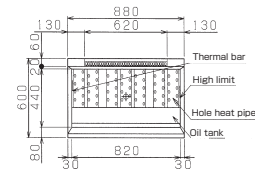

MGF-13WK

List Price : ¥258,000
(tax-excluded)

Oil amount
13ℓ×2

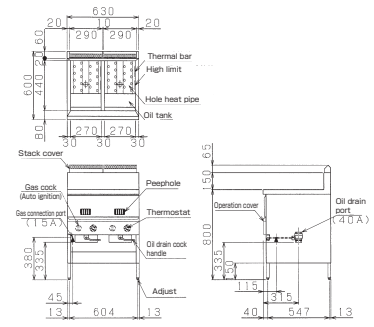

MGF-18WK

List Price : ¥289,000
(tax-excluded)

Oil amount
18ℓ×2

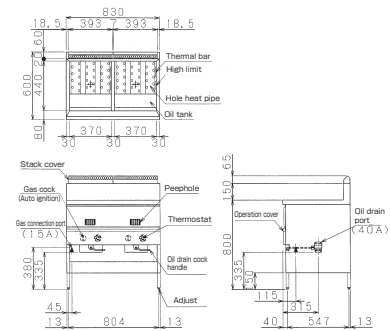

MGF-23WK

List Price : ¥299,000
(tax-excluded)

Oil amount
23ℓ×2

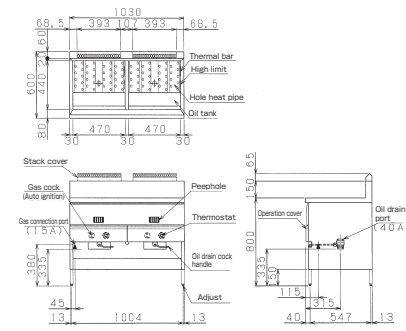

MGF-30WK

List Price : ¥459,000
(tax-excluded)

Oil amount
30ℓ×2

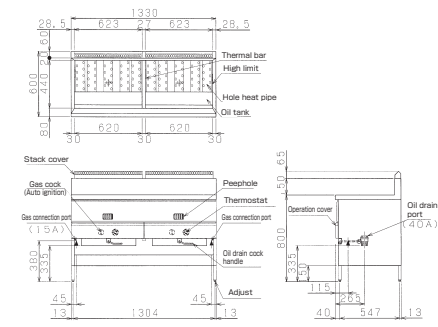

Top series of Maruzen fryer of fully reaching Good Taste, cost and workability.



Oil temperature control without missing the good taste.

The microcomputer control regulates the oil temperature from 100°C to 240 °C by increments of 1°C.

Cooking temperature zone can cope with a wide menu variety, yet resulting in uniform frying, and meeting satisfaction for all aspects such as taste, incense and color. Operation is easy with the touch of the touch panel sheet. In addition, it prevents oil and water from entering the interior.



Good taste is kept by reducing the oxidation of oil.

Proportional control scheme adopted in the burner control, control to optimize the flow rate of the gas. This prevents excessive heating of the oil and suppresses the oxidation of the oil. In addition, with the Maruzen's original special circulation heating method, oil does not become cloudy. Furthermore, since cooking is done in a proper temperature with less portion of the dirt, delicious fried food will be made.

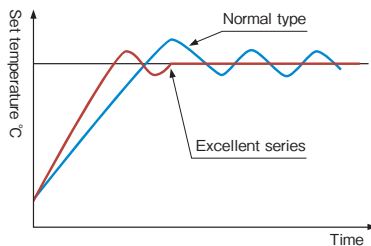

Oil temperature rises quickly even in case of the frozen food.

A Maruzen's original special oval hole heat pipe is adopted. Thermal efficiency has been improved by the strong heat of the burner much further. Oil temperature rises quickly even in case of frozen food.

Moreover, there is no waste to energy, and it is especially effective for energy saving because only the upper layer of the oil tank is heated for cooking.

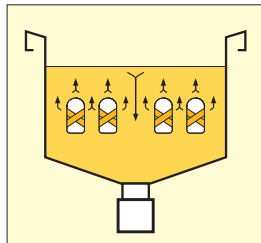

NEW

Regular type is reduced oil amount between 5% to 9%!

Regular type is also equipped with hole heat pipe for high-calorie which had been used only for fast food type. It reduces oil amount between 5% to 9%

Therefore, you can reduce the cost for buying oil and treatment of waste oil.

NEW

All the models are secured a space over 150mm from the ground! Cleanability is dramatically improved!

We made a space from the ground that regular type is 150mm and fast food type is 200mm. That makes cleaning easier.



Design that is easy for clean and working.

Special oval-hole heat pipe is even better to cleanability as well as thermal efficiency. With its shape, it is easier access with hand to the bottom of the oil tank. Bits of batter accumulated can easily be removed. Oil tank is clean with a lid of stainless steel.

Equipped overheating prevention device and pilot safety shut off device.



Option to increase the ease of use.

We have an extensive variety of options such as fried food basket, flat net, and American dog skewer receiver. (Refer to P.15)

Equipped overheating prevention device and pilot safety shut off device.

Gas fryer <Excellent Series> is compatible with the specification of the description of the Minister of Land, Infrastructure and Transport Secretariat Government Buildings Department supervision "public building construction standard specifications" (machine facility equipment work).

Regular type -1-tank



Model Change

MXF-036C

List Price : ¥252,000 (tax-excluded)



Oil amount 14ℓ

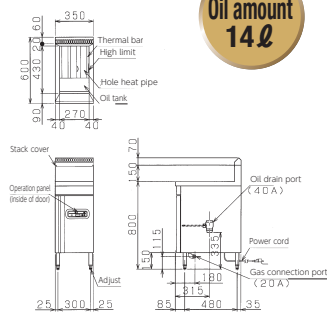

Model Change

MXF-046C

List Price : ¥280,000 (tax-excluded)



Oil amount 19ℓ

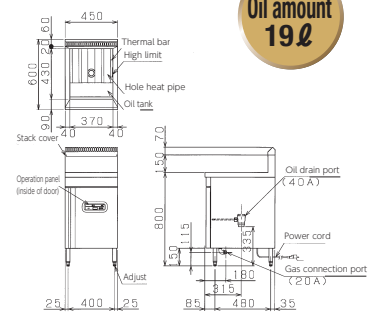

Regular type -1-tank

Please choose according to application and space.

MXF-056C

List Price : ¥327,000
(tax-excluded)

JFEA



Oil amount
24ℓ

Model Change

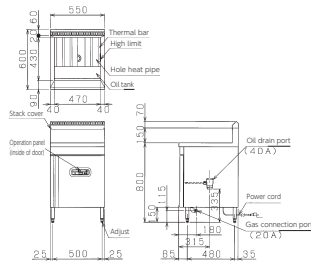

MXF-076C

List Price : ¥409,000
(tax-excluded)

JFEA



Oil amount
31ℓ

Model Change

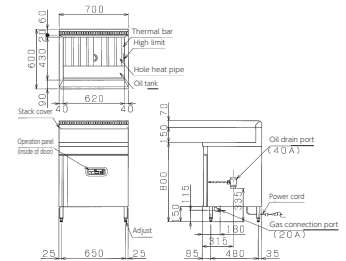

MXF-096C

List Price : ¥454,000
(tax-excluded)

JFEA



Oil amount
41ℓ



Model Change

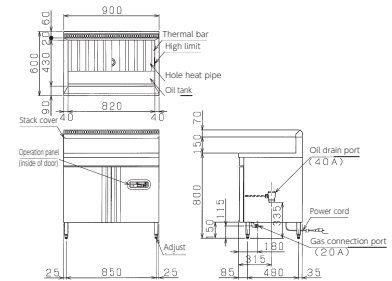

Regular type -2-tank

It is most suitable to perform the deep-fried food of different types.

MXF-076WC

List Price : ¥505,000
(tax-excluded)

JFEA



Oil amount
14ℓ×2



Model Change

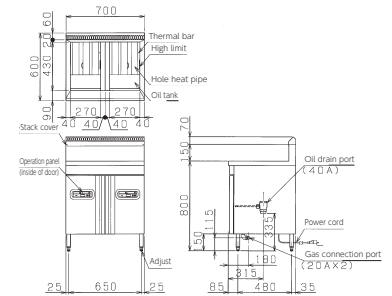

MXF-096WC

List Price : ¥562,000
(tax-excluded)

JFEA



Oil amount
19ℓ×2



Model Change

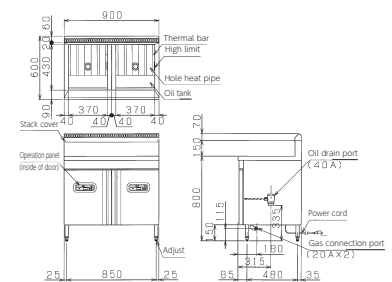

MXF-116WC

List Price : ¥655,000
(tax-excluded)



JFEA



Oil amount
24ℓ×2



Model Change

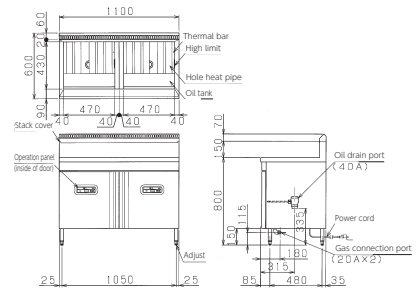

MXF-146WC

List Price : ¥779,000
(tax-excluded)



JFEA



Oil amount
31ℓ×2



Model Change

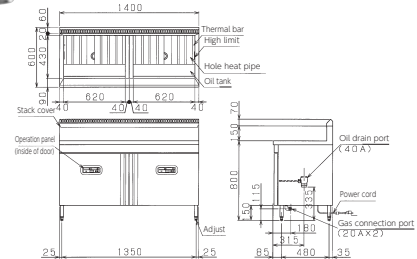

Fast Food type -1-tank

please choose according to Space and quantity of cooking.

● **Quick and delicious for large volume cooking.**

Even a large amount of ingredients are not overlapped thanks to deep oil tank, you can cook quickly without impairing the taste .

● **Continuous cooking in the affluent firepower.**

The fire power of a burner is increased in accordance with the increase of the oil amount. You can continue cooking efficiently, and correspond even when at peak time.

● **Please choose from all six models of 1-2 tank type to meet the needs of our customers.**

MXF-036FC

List Price : ¥298,000
(tax-excluded)



Model Change

JFEA

Oil amount
20ℓ

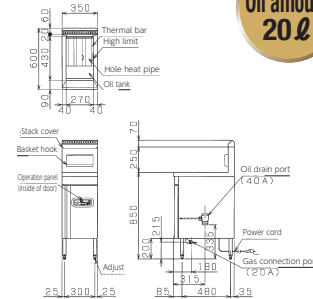

MXF-046FC

List Price : ¥348,000
(tax-excluded)



Model Change

JFEA

Oil amount
28ℓ

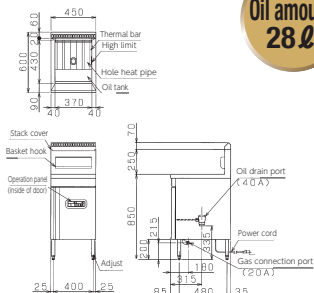

MXF-056FC

List Price : ¥388,000
(tax-excluded)



Model Change

JFEA

Oil amount
36ℓ

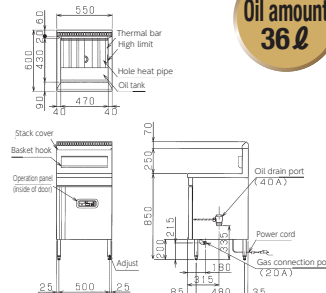

MXF-076FWC

List Price : ¥596,000
(tax-excluded)

JFEA

Oil amount
20ℓ×2



Model Change

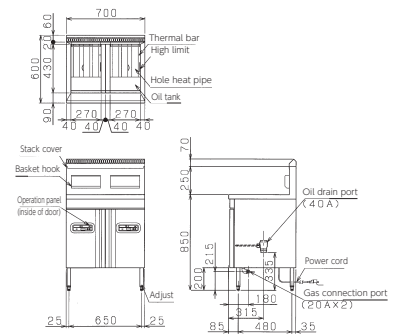

MXF-096FWC

List Price : ¥696,000
(tax-excluded)

JFEA

Oil amount
28ℓ×2



Model Change

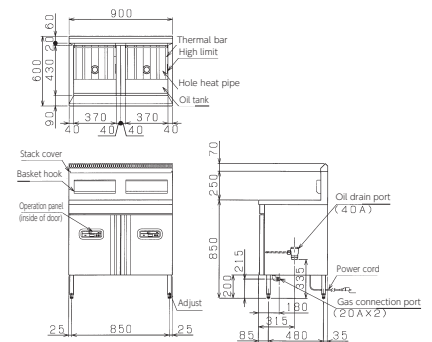

MXF-116FWC

List Price : ¥776,000
(tax-excluded)

JFEA

Oil amount
36ℓ×2



Model Change

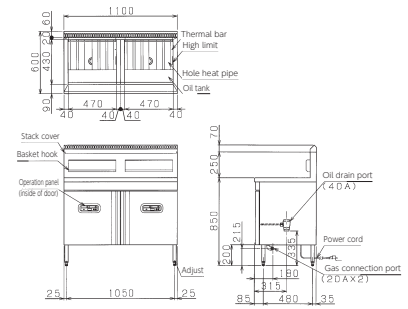

Tofu type

- deep-fried tofu, fried tofu, and Ganmodoki (deep-fried tofu mixed with thinly sliced vegetables), tofu menu -only model.
- 2-tank type that is selectively used as high/low temperature tank can perform temperature control in the range of 100°C ~240°C.
- Considering the juicy deep-fried tofu, it is equipped with a high efficiency hole heat pipe for tofu type only.

Model Change

MXF-118TFC

List Price : ¥698,000
(tax-excluded)



Oil amount
20ℓ×2

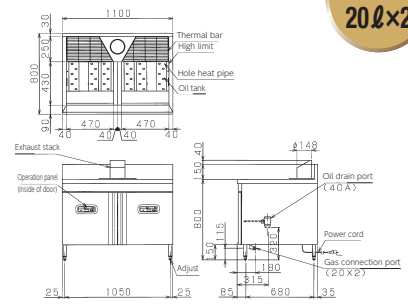

Gas Fryer <Excellent Series> Specifications Table

Model	External dimension (mm)					Door number	Oil amount (ℓ)	Gas consumption		Gas connection	Power consumption 1φ100V 50/60Hz (W)	Power cord	Weight (kg)	Accessories																
	Width	Depth	Height	Height back	Town gas			LP gas	Cover					Partition net	Oil tank	Oil screen	Skimming net	Sliding plate	Oil drain plate	Oil drain net	Fried food basket A	Basket hook	Divider							
Regular type	MXF-036C	350	600	800	150	1	14	7.56kW(6,500kcal/h)	7.56kW(0.54kg/h)	20A	20	2.5m with plug (ground adapter) (⚡)	46	1	1	S1	1	1	1	1	1									
	MXF-046C	450	600	800	150	1	19	10.5kW(9,000kcal/h)	10.5kW(0.75kg/h)	20A	20		53	1	1	L1	1	1	1	1	1									
	MXF-056C	550	600	800	150	1	24	12.8kW(11,000kcal/h)	12.2kW(0.88kg/h)	20A	20		61	1	1	S2	2	1	1	1	1									
	MXF-076C	700	600	800	150	1	31	18.0kW(15,500kcal/h)	17.4kW(1.25kg/h)	20A	20		75	1	1	S1,L1	2	1	1	1	1									
	MXF-096C	900	600	800	150	2	41	22.7kW(19,500kcal/h)	19.8kW(1.42kg/h)	20A	20		86	1	1	L2	2	1	1	1	1									
	MXF-076WC	700	600	800	150	2	14×2	15.1kW(13,000kcal/h)	15.1kW(1.08kg/h)	20A×2	40		81	1	2	S2	2	2	2	1	1									
	MXF-096WC	900	600	800	150	2	19×2	20.9kW(18,000kcal/h)	20.9kW(1.50kg/h)	20A×2	40		95	1	2	L2	2	2	2	1	1									
	MXF-116WC	1,100	600	800	150	2	24×2	25.6kW(22,000kcal/h)	24.4kW(1.75kg/h)	20A×2	40		110	2	2	S2,L1	3	2	2	1	1									
	MXF-146WC	1,400	600	800	150	2	31×2	36.0kW(31,000kcal/h)	34.9kW(2.50kg/h)	20A×2	40		131	2	2	L3	3	2	2	1	1									
Fast Food type	MXF-036FC	350	600	850	250	1	20	11.6kW(10,000kcal/h)	9.88kW(0.71kg/h)	20A	20		49	1	1	S1	1							2	1					
	MXF-046FC	450	600	850	250	1	28	15.1kW(13,000kcal/h)	13.4kW(0.96kg/h)	20A	20		56	1	1	L1	1							2	1					
	MXF-056FC	550	600	850	250	1	36	17.4kW(15,000kcal/h)	14.5kW(1.04kg/h)	20A	20		69	1	1	S2	2							3	1					
	MXF-076FC	700	600	850	250	2	20×2	23.3kW(20,000kcal/h)	19.8kW(1.42kg/h)	20A×2	40		90	1	2	S2	2							4	2					
	MXF-096FC	900	600	850	250	2	28×2	30.2kW(26,000kcal/h)	26.7kW(1.92kg/h)	20A×2	40		104	1	2	L2	2							4	2					
MXF-116FC	1,100	600	850	250	2	36×2	34.9kW(30,000kcal/h)	29.1kW(2.08kg/h)	20A×2	40	123		2	2	L3	3							6	2						
Tofu type	★MXF-118TFC	1,100	800	800	150	2	20×2	25.6kW(22,000kcal/h)	24.4kW(1.75kg/h)	20A×2	40		117	2		L2	2	2					2					2		

★It is about 2 weeks for the delivery time after an order delivery model marked.

Accessories

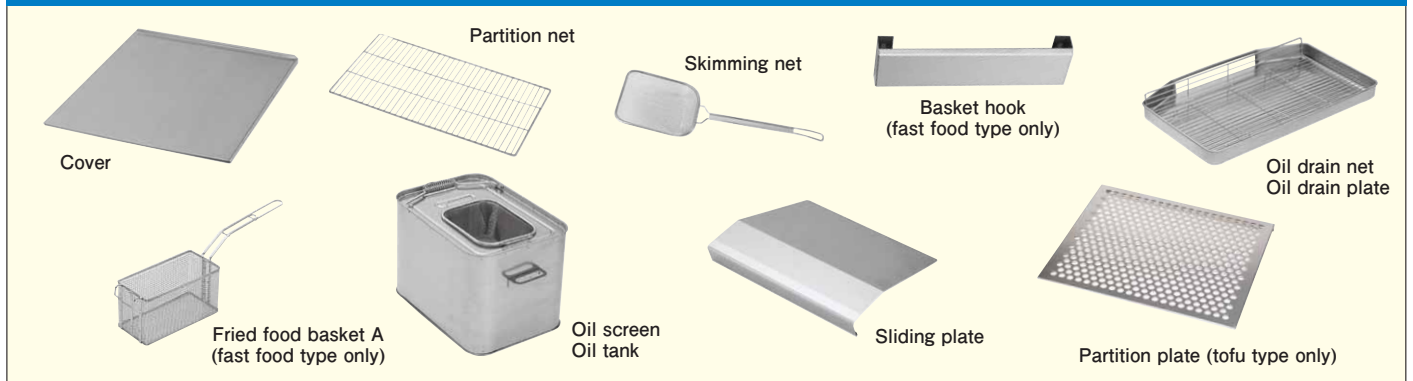

●There may have different sizes and specs depending on the model.

Option

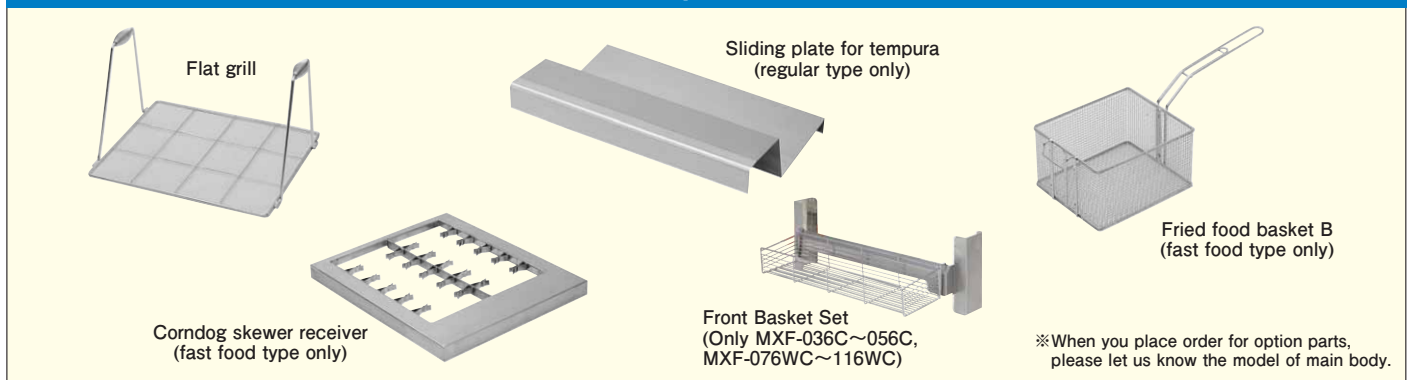

※When you place order for option parts, please let us know the model of main body.



"Auto Lift" and "Menu Program Function" are equipped! Ideal gas fryer for delicatessen corner in super market!

OSAKA GAS, LTD. joint development



- Whole oil tank is covered with heat insulator and air heat-insulation layer is provided around the oil tank. This allows the optimized air flow inside the device to take the heat of the body and finally to suppress the radiant heat from the device and reduce the surface temperature rise.
- Removable heat protector is provided at front rail which is easy to access for cooker during cooking. This protector reduces the radiant heat and enhances safety when touching the front rail.



涼厨 (Suzuchu)

"Suzuchu equipment"

is the certified gas appliances that are designed to resist heating up room temperature by exhausting intensively and insulating hot part to lower the radiant heat on the surface of equipment. Therefore, the temperature is kept low so you can touch and convert the work place much more comfortable and safer. ("Suzuchu" is a trademark and 「涼厨」 is the registered trademark of Osaka Gas.)

Exhaust stack (right) and heat protector (left).

Arrow shows the airflow reducing the heat from the body.



Lift up at the best timing for tasty. The melody will notice you the end of cooking.

The fry baskets lift up automatically at the set time. It is effective for labor saving, because even part time workers can cook easily. Electric melody will notice you when the end of cooking comes closer, which can prevent missing the best timing for fresh fried. Also, if you want to fry more, you can extend for each 10 seconds with one-touch operation.



Lift-up State

99 menus can be registered! "Double Frying" can be programmed!

Cooking program can be registered up to 99 menus. Not only the oil temperature (Between 100 to 220°C) and cooking time (Between 0 sec to 99 min 59 sec), but also "Double Frying" can be programmed in advance. Your original taste and labor saving can be realized at the same time. Melody for the end of cooking can be chosen from 7 patterns. Therefore, it is easy to recognize the equipment when you use several units.



Large hole heat pipe with excellent thermal efficiency.

Special-circulated heating method by large hole heat pipe realizes excellent thermal efficiency (in-house Product Comparison). Moreover, there is no waste to energy by heating the upper layer only of oil tank for cooking. It is energy saving. Additionally, oil temperature can be heated faster with possibility of speedy service even during peak time.

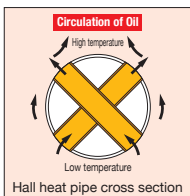

Control panel separated type which is very useful.

Control panel is separate type and equipped just in front of the cooking staff. You can handle the panel without bending down, so it is easy to handle and check the oil temperature while cooking. You can choose the location of panel left or right.



Easy-to-Clean Oil Tank Construction.

It is easy to clean because the bottom of the oil tank can be easily reached with a hand. Turn the oil drain cock to drain oil into the waste oil tank with casters.



Eco mode realizes energy saving reducing the oil oxidized

Right after pushing ECO button, it is switched to eco mode which keeps the oil temperature lower than the set temperature. That realizes not only preventing oil oxidized but also energy saving. Also, setting is available to switch to eco mode automatically when constant time passes over without cooking. Please contact us for details.

Equipped overheating prevention device and pilot safety shut off device.

Oil Circulation Prevents Oxidization for Good Frying.

Oil inside the tank circulates at all times to prevent uneven heating and oxidization. Fried scraps sink to the lower temperature area so it is possible to always cook in the clean area at a proper temperature.

Auto Lift type

MGF-CDL27BL(R)

List Price : ¥664,000
(tax-excluded)



Oil amount
27 ℓ



※ This picture is for control panel on right side type

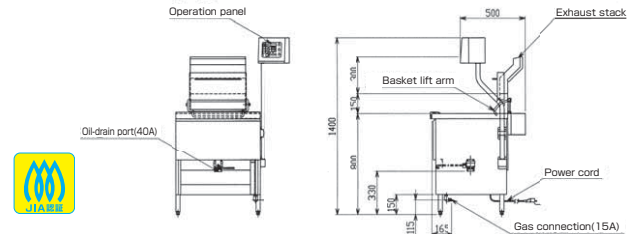
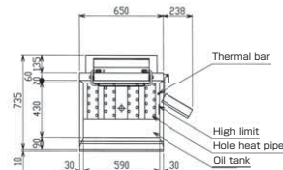

Gas Fryer <Suzuchu> for Delicatessen specification table

Model	External dimension (mm)				Oil amount	Gas consumption		Gas connection	Power (50/60H)	Power consumption	Power cord	Weight (kg)	Accessories
	Width	Depth	Height	Height back		Town gas	LP gas						
MGF-CDL27BL(R)	650(888)	735	800 (1400)	150	27ℓ	14.0kW (12,000kcal/h)	14.0kW (1.00kg/h)	15A	1ø100V	75W	1.5m with plug (Ground adapter) (⚠)	77	Partition net, Oil tank(S2), Oil screen(S2), Skimming net, Fried food basket,Cover

※ Size in () includes control panel.
We have R type (control panel located right side) and L type (control panel located left side) for each items.

Standard type

Non-Auto Lift type for cooking Tempura

MGF-CD27BL(R)

List Price : ¥358,000
(tax-excluded)



Oil amount
27 ℓ



※ This picture is for control panel on left side type

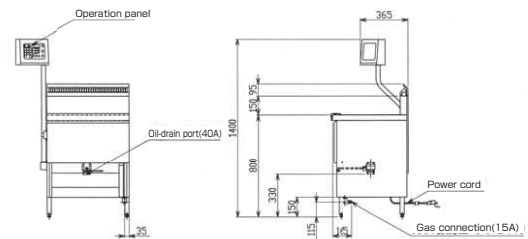
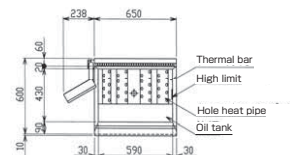

Gas Fryer <Suzuchu> for Delicatessen specification table

Model	External dimension (mm)				Oil amount	Gas consumption		Gas connection	Power (50/60H)	Power consumption	Power cord	Weight (kg)	Accessories
	Width	Depth	Height	Height back		Town gas	LP gas						
MGF-CD27BL(R)	650(888)	600	800 (1400)	150	27ℓ	14.0kW (12,000kcal/h)	14.0kW (1.00kg/h)	15A	1ø100V	25W	1.5m with plug (Ground adapter) (⚠)	66	Partition net, Oil tank(S2), Oil screen(S2), Skimming net, Sliding plate, Oil drain plate, Oil drain net, Cover

※ Size in () includes control panel.
We have R type (control panel located right side) and L type (control panel located left side) for each items.

Accessories

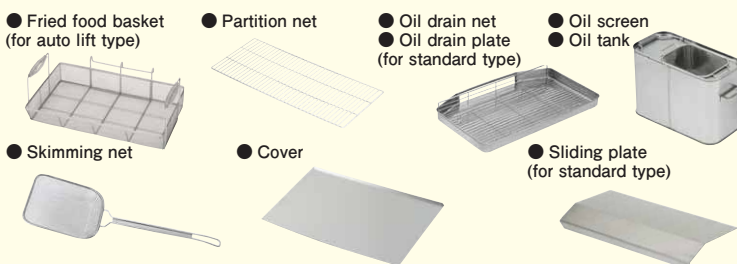

Options

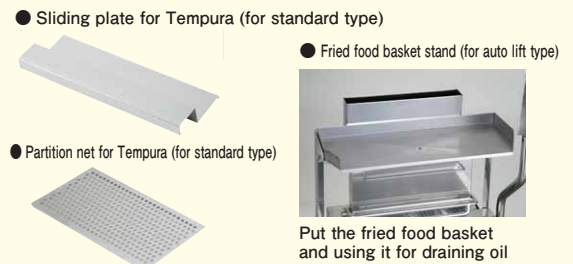

※ There may have different sizes and specs depending on the model.



Excellent safety and wide variety of cooking function are equipped! Electric Fryer which can cook tasty fried food by far infrared!

Safety by slow down function! Swung up heater turns off electricity automatically!

When you lift down the heater back to the original position, it will not fall down quickly but slowly goes down. It can prevent the heater fall down to oil, and you don't have to worry about your skin burn. Moreover, lifted heater stops energization automatically, which drastically reduce the dangerousness of skin burn. The safety when you clean up is drastically improved. (Except for Electric mini fryer and table top fast food type)



Deliciously fried with extreme-infrared effect.

Extreme-infrared radiation from the heater heats evenly. This also suppresses the deterioration of the oil and achieves delicious cooking without missing the flavor of the food.



Useful "Melt Function" to use the solid oil. (Lard heating)

Melt function (lard heating) to gradually dissolve solid oil is equipped. It is very useful when you use solid oil such as lard. (Only for the model microcomputer equipped)

The cleaning is simple for swing-up method heater.

You can swing up the heater unit, making it easy to clean and replace the oil. The inside of oil tank has no protrusions, so the design is easy for cleaning.

A swing-up heater comes with a stopper (except for the electric mini fryer).



Perfect for floor cleaning

Leg part of main body is round pipe which makes cleaning easier. Moreover, there is a wide space under the equipment, so you can use cleaning tools like mops easily, which is perfect for floor cleaning.



Electric fryer is offered with a type that conforms to the specification of the description of the Minister of Land, Infrastructure and Transport Secretariat Government Buildings Department supervision "public building construction standard specifications" (machine equipment work).

Temperature of oil and frying time can be set!

The oil temperature (Between 100 to 220°C) and frying time (Timer: Between 0 sec to 99 min 59 sec) can be set in advance (Max.99 menus). Also, frying time can be changed temporarily by manual switch. The melody for finish cooking can be chosen from 7 patterns. Therefore, even if using several units, the melody can be different for each equipment, which is very useful for recognition when finish frying. (Only for the model microcomputer equipped)

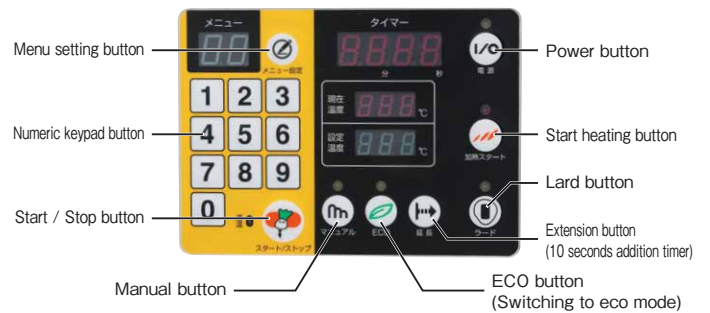

Eco mode realizes energy saving reducing the oil oxidized

Right after pushing ECO button, it is switched to eco mode which keeps the oil temperature lower than the set temperature. That realizes not only preventing oil oxidized but also energy saving. Also, setting is available to switch to eco mode automatically when constant time passes over without cooking. Please contact us for details. (Only for the model microcomputer equipped)

Foldable cover can be put under the body.

Cover of oil tank is foldable and can be put under the body. You don't need to concern about the place for putting it. (Except for table top type)



Safe with overheating prevention mechanism.

It is equipped with a mechanism to prevent overheating with a built-in high limit switch to cut off the circuit automatically if the oil temperature rises abnormally. In addition, the built-in high limit switch cuts off the circuit even when there is abnormal condition in the main body of the high limit switch, so it is safer.



Cooking ability table (MEF-18E)

Cooking name	Cooked amount per once	Proper oil temperature	Cooking time	Capacity/h
Croquette (raw 50g)	15~21 pieces	180~200°C	2~3 minutes	250~350 pieces
Pork cutlet	16~20 pieces	180~190°C	2~4 minutes	200~250 pieces
Horse mackerel tempura	28~36 pieces	180~190°C	2~4 minutes	350~450 pieces
Vegetable tempura	12~31 pieces	160~180°C	1~3 minutes	200~500 pieces
French fries (frozen)	1.2kg	180°C	4 minutes	15kg
Fried chicken	1.2kg	180~190°C	3~6 minutes	10kg

※required time will be 30~50% increased in the case of frozen food.

Electric fryer



- Compact design to make effective use of the limited space
- Popular deep-fried food becomes handy at table counter.
- Outstanding performance in a banquet, a demonstration corner, event and so on.

Control Panel
(thermostat
specification)



Electric mini fryer

**Ultra-small fryer that can be used in 100V!
It is ideal for hot snacks of CVS without choosing a location.**

Lightweight compact body with 255mm in frontage.
1φ100V power can be used without choosing the installation location.
Outstanding performance in a banquet, a demonstration corner, event and so on.

Oil tank and the heater unit is removable.

Since the oil tank and the heater unit can be easily removed, it is easier for cleaning, and the cleaning of day-to-day is easy.

MEF-M8T (Front basket specification)

List Price : ¥94,000
(tax-excluded)

1φ100V

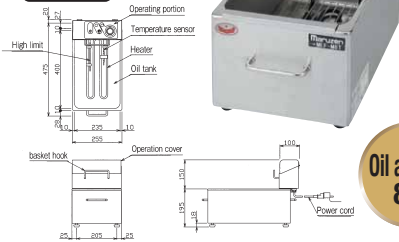

Oil amount
8ℓ

MEF-M8FT (Fried food basket specification)

List Price : ¥95,000
(tax-excluded)

1φ100V

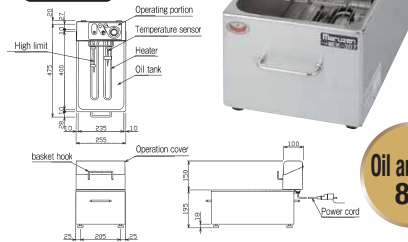

Oil amount
8ℓ



Table top type -1-tank Compact desing that can be installed anywhere

MEF-3TAE

List Price : ¥148,000
(tax-excluded)

1φ100V

Oil amount
3ℓ

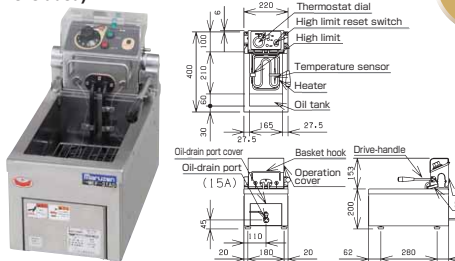

MEF-5TAE

List Price : ¥198,000
(tax-excluded)

1φ100V

Oil amount
5ℓ

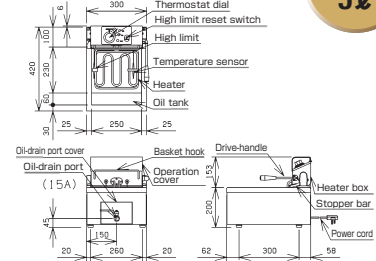

MEF-5TE

List Price : ¥208,000
(tax-excluded)

Oil amount
5ℓ



MEF-8TE

List Price : ¥238,000
(tax-excluded)

Oil amount
8ℓ

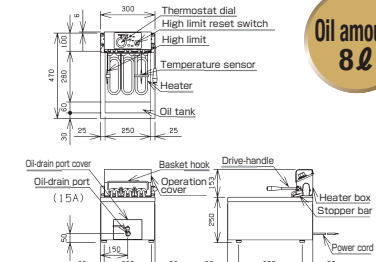

MEF-10TE

List Price : ¥258,000
(tax-excluded)

Oil amount
10ℓ



MEF-13TE

List Price :
¥308,000
(tax-excluded)



Oil amount
13ℓ



Electric fryer

Table top fast food type -1-tank

MEF-10TPD

List Price : ¥230,000
(tax-excluded)

Oil amount
10ℓ

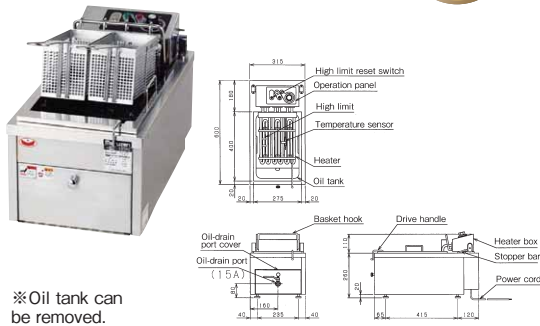

※Oil tank can be removed.

Table top fast food type -2-tank

MEF-10TPWD

List Price : ¥440,000
(tax-excluded)

Oil amount
10ℓx2

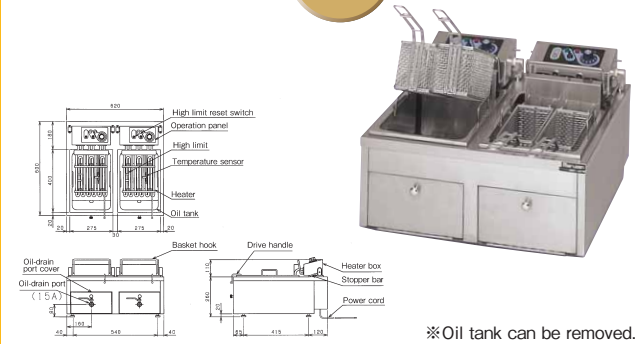

※Oil tank can be removed.

Regular type -1-tank Depending on space and the amount of cooking

MEF-13E

List Price : ¥390,000
(tax-excluded)



Oil amount
13ℓ

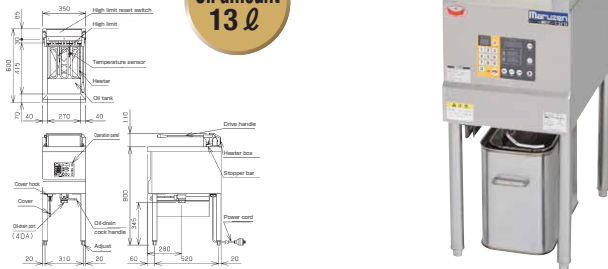

MEF-18E

List Price : ¥448,000
(tax-excluded)



Oil amount
18ℓ



MEF-23E

List Price : ¥518,000
(tax-excluded)



Oil amount
23ℓ

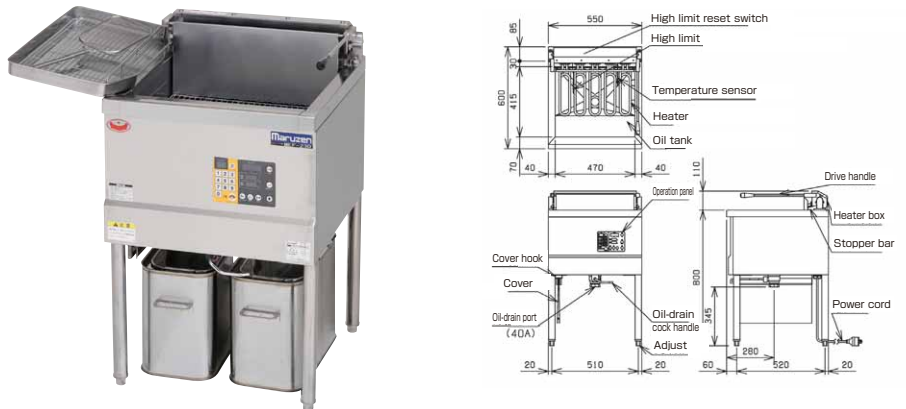

MEF-27E

List Price : ¥585,000
(tax-excluded)



Oil amount
27ℓ

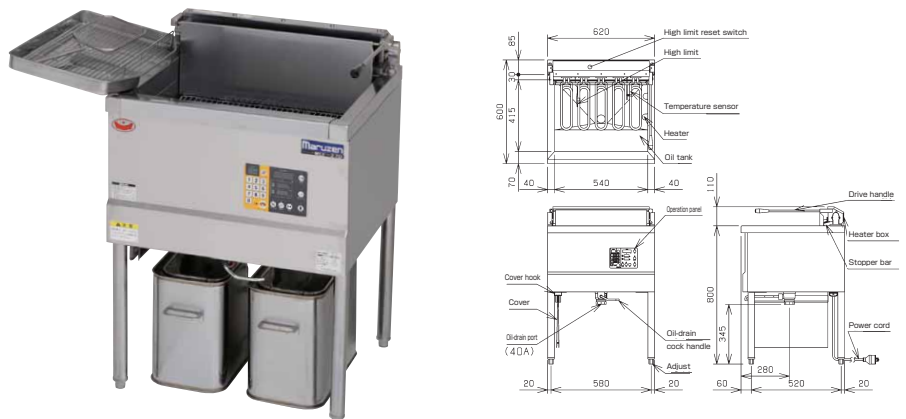

Electric fryer



Regular type -2-tank

MEF-13WE

List Price : ¥745,000
(tax-excluded)



Oil amount
13 ℓ x2

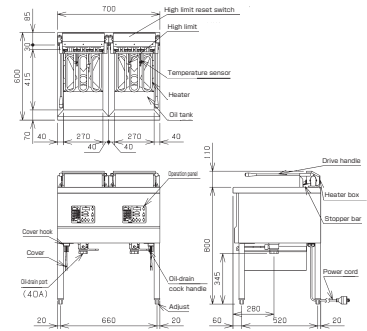

MEF-18WE

List Price : ¥860,000
(tax-excluded)



Oil amount
18 ℓ x2

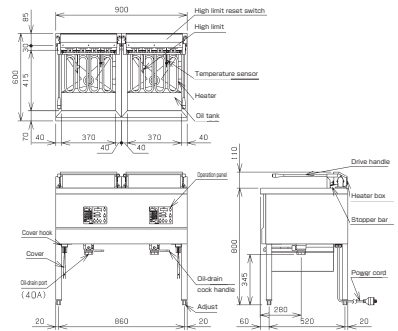

MEF-23WE

List Price : ¥990,000
(tax-excluded)



Oil amount
23 ℓ x2

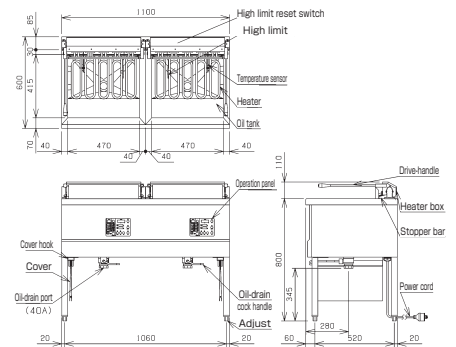

Fast food type -1-tank

MEF-13FE

List Price : ¥430,000
(tax-excluded)



Oil amount
18 ℓ

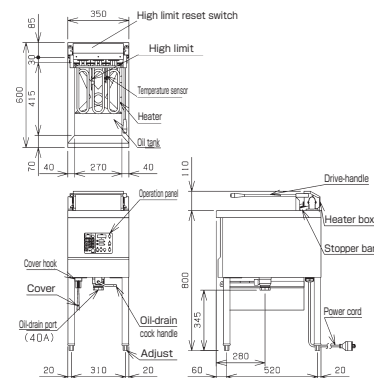

Lift up at the best timing for deliciousness! Best taste and labor saving realized at the same time!



**Lift up at the best timing for tasty.
The melody will notice you the end of cooking.**

The fry baskets lift up automatically at the set time. It is effective for labor saving, because even part time workers can cook easily. Electric melody will notice you when the end of cooking comes closer, which can prevent missing the best timing for fresh fried. Also, if you want to fry more, you can extend for each 10 seconds with one-touch operation.



Eco mode realizes energy saving reducing the oil oxidized

Right after pushing ECO button, it is switched to eco mode which keeps the oil temperature lower than the set temperature. That realizes not only preventing oil oxidized but also energy saving. Also, setting is available to switch to eco mode automatically when constant time passes over without cooking. Please contact us for details.

Useful "Melt Function" to use the solid oil. (Lard heating)

Melt function (lard heating) to gradually dissolve solid oil is equipped. It is very useful when you use solid oil such as lard.

Far infrared sheath heater can cook tasty fried food.

99 menus can be registered! "Double Frying" can be programmed!

Cooking program can be registered up to 99 menus. Not only the oil temperature (Between 100 to 220°C) and cooking time (Between 0 sec to 99 min 59 sec), but also step cooking such as "Double Frying" can be programmed in advance. Your original taste and labor saving can be realized at the same time. Melody for the end of cooking can be chosen from 7 patterns. Therefore, it is easy to recognize the equipment when you use several units.



Swing up type heater & removable oil tank type can realize easy cleaning

Changing oil and cleaning oil tank are easy by swing up heater. Moreover, oil tank is removable and daily cleaning is very easy.



Safe with overheating prevention mechanism.

MEF-3TALE 1φ100V

List Price : ¥236,000
(tax-excluded)

Oil amount 3ℓ

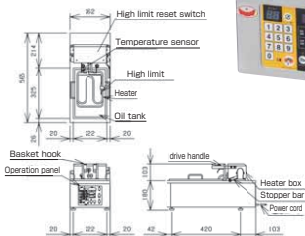

MEF-5TLE

List Price : ¥298,000
(tax-excluded)

Oil amount 5ℓ

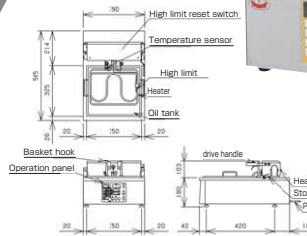

MEF-8TLE

List Price : ¥348,000
(tax-excluded)

Oil amount 8ℓ

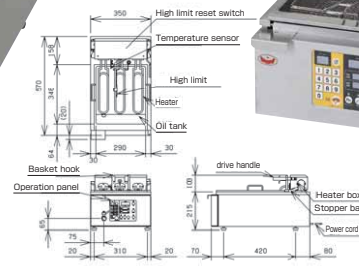

Electric auto lift fryer Specification Table

■ It takes 3 weeks to be produced

Model	External dimension(mm)			Oil amount (ℓ)	Power (50/60Hz)	Powerconsumption (kW)	Necessary hand switch capacity	Power cord	Weight (kg)	Accessories
	Width	Depth	Heghth							
MEF-3TALE	262	565	180	3	1 φ 100V	1.4	—	2m with plug(ground adapter) Ⓢ	15	Cover, Partition net, Fried food basket, Net for taking oil debris
MEF-5TLE	390	565	180	5	1 φ 200V	2.2	15A	2m 1.25mm ² -3core direct connecting	16.5	Cover, Partition net, Fried food basket, Net for taking oil debris
MEF-8TLE	350	570	215	8	3 φ 200V	3.4	15A	2m 2mm ² -4core direct connecting	18	Cover, Partition net, Fried food basket, Net for taking oil debris, Coupler formura oil drain flexible hose

Accessories

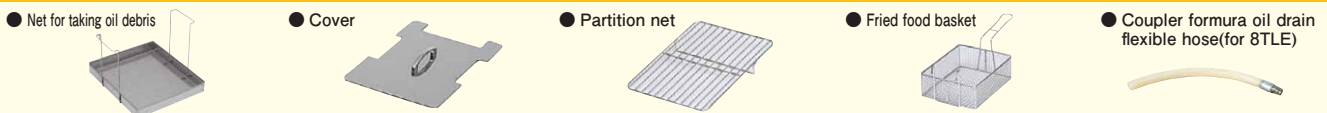

※ There may have different sizes and specs depending on the model. ● Prepared with skimming net(small) for 3TALE as option.

**Excellent safety and wide variety of cooking function!
Ideal fryer for cooking in delicatessen corner!**



■ Cooking ability table (MEF-D18B)

Cooking name	Cooked amount per once	Proper oil temperature	Cooking time	Capacity/h
Croquette (raw 50g)	15~21 pieces	180~200°C	2~3 minutes	250~350 pieces
Pork cutlet	16~20 pieces	180~190°C	2~4 minutes	200~250 pieces
Horse mackerel tempura	28~36 pieces	180~190°C	2~4 minutes	350~450 pieces
Vegetable tempura	12~31 pieces	160~180°C	1~3 minutes	200~500 pieces
French fries (frozen)	1.2kg	180°C	4 minutes	15kg
Fried chicken	1.2kg	180~190°C	3~6 minutes	10kg

※required time will be 30-50% increased in the case of frozen food.



Electric Fryer for Delicatessen is offered with a type that conforms to the specification of the description of the Minister of Land, Infrastructure and Transport Secretariat Government Buildings Department supervision "public building construction standard specifications"(machine knitting equipment work).

Excellent safety is realized by "slow down function"!

When you lift down the heater back to the original position, it will not fall down quickly but slowly goes down. It can prevent the heater fall down to oil, and you don't have to worry about your skin burn. Moreover, lifted heater stops energization automatically, which drastically reduce the dangerousness of skin burn. The safety when you clean up is drastically improved.



99 menus can be registered! "Double Frying" can be programmed!

Cooking program can be registered up to 99 menus. Not only the oil temperature (Between 100 to 220°C) and cooking time (Between 0 sec to 99 min 59 sec), but also step cooking such as "Double Frying" can be programmed in advance. Your original taste and flavor saving can be realized at the same time. Melody for the end of cooking can be chosen from 7 patterns. Therefore, it is easy to recognize the equipment when you use several units.

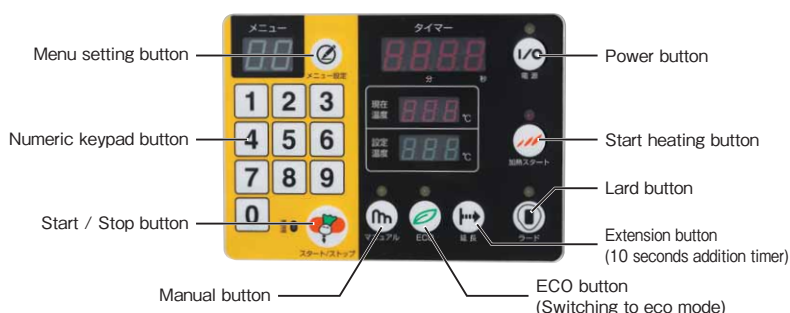

Multi functions and easy cleaning! 36 models in total!

Lift up at the best timing for tasty. The melody will notice you the end of cooking.

The fry baskets lift up automatically at the set time. It is effective for labor saving, because even part time workers can cook easily. Electric melody will notice you when the end of cooking comes closer, which can prevent missing the best timing for fresh fried. Also, if you want to fry more, you can extend for each 10 seconds with one-touch operation.



Eco mode realizes energy saving reducing the oil oxidized

Right after pushing ECO button, it is switched to eco mode which keeps the oil temperature lower than the set temperature. That realizes not only preventing oil oxidized but also energy saving. Also, setting is available to switch to eco mode automatically when constant time passes over without cooking. Please contact us for details.

Easy cleaning with swing-up method cartridge heater

You can swing up the heater, making it easy to clean and replace the oil. Cartridge heater is simple shape which is easy to be cleaned.



Perfect for floor cleaning

Leg part of main body is round pipe which makes cleaning easier. Moreover, there is a wide space under the equipment, so you can use cleaning tools like mops easily, which is perfect for floor cleaning.



A variety of lineups

We have 3 types for control panel; "Control panel at front type" which is standard, "Control panel at left and right separated type" which is just in front of you and easy to use, and "Control panel at upper part type" which is simple layout and space-saving.



Front Panel type



Left and Right Separated type



Upper Part type

Foldable cover can be put under the body.

Cover of oil tank is foldable and can be put under the body. You don't need to concern about the place for putting it.



Useful "Melt Function" to use the solid oil. (Lard heating)

Melt function (lard heating) to gradually dissolve solid oil is equipped. It is very useful when you use solid oil such as lard.

Overheating prevention device is equipped and safe

The overheating prevention device is equipped, which automatically and safely stops heating in case oil temperature rises abnormally.



Easy Cleaning Table set type is available

Table set type is available, which has a wide space around the leg part and easy to clean when you use several units together.



Wide space around the leg part

Control panel at front type

Control panel at front type which is standard

MEF-DL18B

List Price : ¥708,000
(tax-excluded)



Oil amount
18ℓ

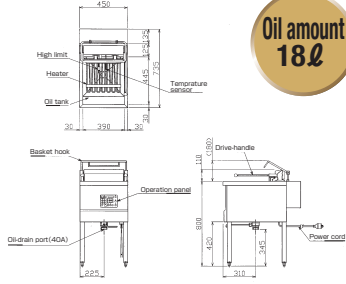

MEF-DL23B

List Price : ¥878,000
(tax-excluded)



Oil amount
23ℓ

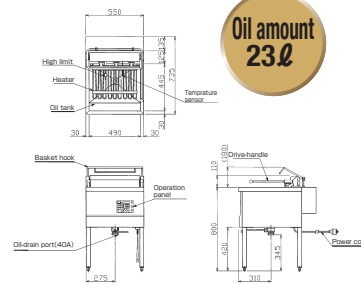

MEF-DL27B

List Price : ¥949,000
(tax-excluded)



Oil amount
27ℓ

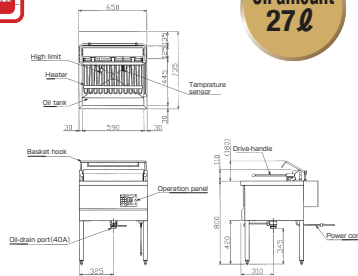

Control panel at left and right separated type

Control panel at left and right separated type which is just in front of you and easy to use

MEF-DL18BL(R)

List Price : ¥788,000
(tax-excluded)



Oil amount
18ℓ

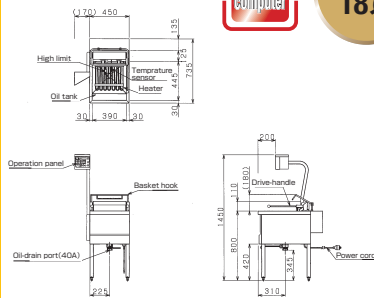

※ This picture is for control panel on left side type

MEF-DL23BL(R)

List Price : ¥958,000
(tax-excluded)



Oil amount
23ℓ

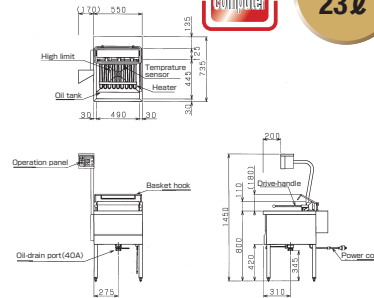

※ This picture is for control panel on left side type

MEF-DL27BL(R)

List Price : ¥1,029,000
(tax-excluded)



Oil amount
27ℓ

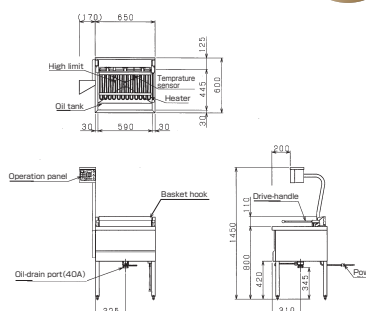

※ This picture is for control panel on left side type

R in the end of model name means control panel on right side type.

MEF-DL27BR

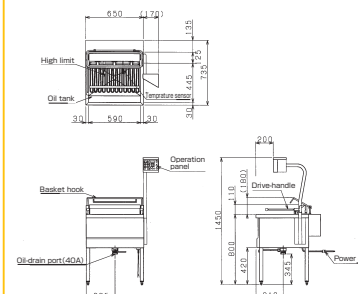

Control panel at upper part type which is simple layout and space-saving

MEF-DL18BU

List Price : ¥788,000
(tax-excluded)



Oil amount
18 ℓ

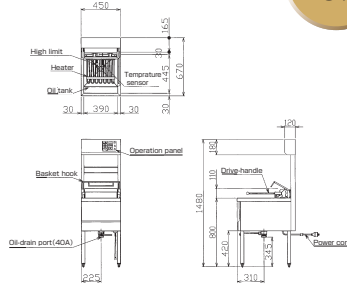

MEF-DL23BU

List Price : ¥958,000
(tax-excluded)



Oil amount
23 ℓ

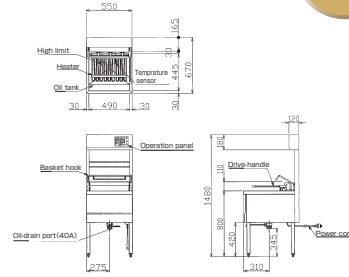

MEF-DL27BU

List Price : ¥1,029,000
(tax-excluded)



Oil amount
27 ℓ

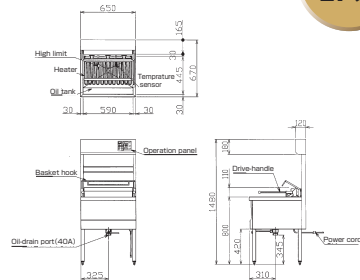

Electric Fryer for Delicatessen <Auto Lift type> Specification Table

■ It takes 2 weeks to be produced

Model	External dimension (mm)			Oil amount (ℓ)	Power (50/60Hz)	Power consumption (kW)	Necessary hand switch capacity	Power cord	Weight (kg)	Accessories						
	Width	Depth	height							Cover	Partition net	Skimming net	Oil tank	Oil screen	Fried food basket	
Control panel at front type	MEF-DL18B	450	735	800	18	3 φ 200V	5.95	20A	2m ground 3P 20A with hook plug	55	1	1	1	L1	1	1
	MEF-DL23B	550	735	800	23	3 φ 200V	7.9	30A	2m ground 3P 30A with hook plug	62	1	1	1	S2	2	1
	MEF-DL27B	650	735	800	27	3 φ 200V	9.85	40A	2m 8mm ² -4 core direct connecting	67	1	1	1	S2	2	1
Control panel at left and right separated type	MEF-DL18BL (R)	450 (620)	735	800 (1450)	18	3 φ 200V	5.95	20A	2m ground 3P 20A with hook plug	58	1	1	1	L1	1	1
	MEF-DL23BL (R)	550 (720)	735	800 (1450)	23	3 φ 200V	7.9	30A	2m ground 3P 30A with hook plug	65	1	1	1	S2	2	1
	MEF-DL27BL (R)	650 (820)	735	800 (1450)	27	3 φ 200V	9.85	40A	2m 8mm ² -4 core direct connecting	70	1	1	1	S2	2	1
Control panel at upper part type	MEF-DL18BU	450	670	1480	18	3 φ 200V	5.95	20A	2m ground 3P 20A with hook plug	55	1	1	1	L1	1	1
	MEF-DL23BU	550	670	1480	23	3 φ 200V	7.9	30A	2m ground 3P 30A with hook plug	62	1	1	1	S2	2	1
	MEF-DL27BU	650	670	1480	27	3 φ 200V	9.85	40A	2m 8mm ² -4 core direct connecting	67	1	1	1	S2	2	1

※ Dimensions in () include the operating unit.

Accessories	Options for Front Panel type and Left and Right Separated type	Options for Upper Part type
<ul style="list-style-type: none"> ● Cover ● Skimming net ● Oil tank ● Oil screen ● Partition net ● Fried food basket 	<ul style="list-style-type: none"> ● Oil drain plate set that is put at upper position. ● Fitting plate ● Fry Basket Holder 	<ul style="list-style-type: none"> ● Oil drain plate set that is put at upper position. ● Fry Basket Holder (Control panel at upper part type) ● Fitting plate

※ There may have different sizes and specs depending on the model.

Easy Cleaning Table set type is available!!

Perfect for floor cleaning!

Table set type is available, which has a wide space around the leg part and easy to clean when you use several units together. Floor cleaning under the body becomes easier, so it is more hygienic.

Electric Fryer for Delicatessen <Auto Lift type>



Wider space around the leg

Control panel at front type

Table set type

MEF-DLK27BW

Table set type

List Price : ¥1,928,000
(tax-excluded)



Oil amount
27ℓ × 2

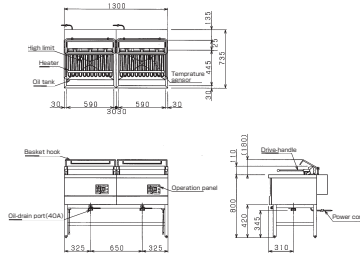

MEF-DLK18BW

Table set type

List Price : ¥1,446,000
(tax-excluded)



Oil amount
18ℓ × 2

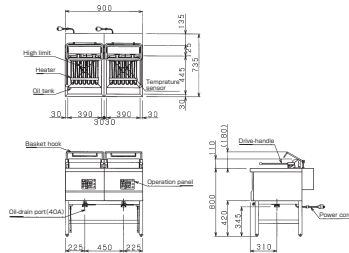

MEF-DLK23BW

Table set type

List Price : ¥1,786,000
(tax-excluded)



Oil amount
23ℓ × 2

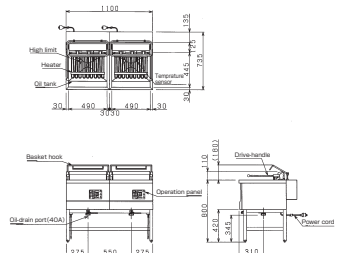

Control panel at left and right separated type

MEF-DLK27BSW

Table set type

List Price : ¥2,088,000
(tax-excluded)



Oil amount
27ℓ × 2

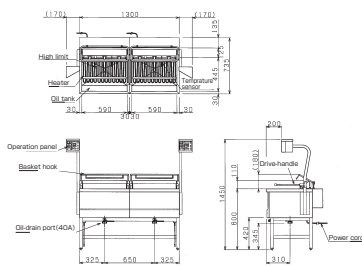

MEF-DLK18BSW

Table set type

List Price : ¥1,606,000
(tax-excluded)



Oil amount
18ℓ × 2

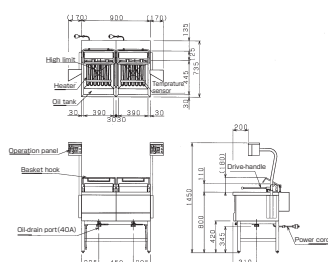

MEF-DLK23BSW

Table set type

List Price : ¥1,946,000
(tax-excluded)



Oil amount
23ℓ × 2

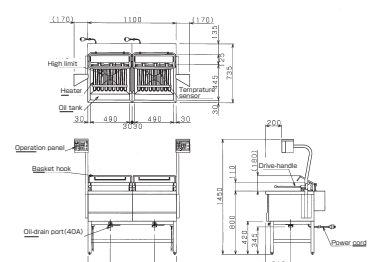

MEF-DLK27BUW

Table set type

List Price : ¥2,088,000
(tax-excluded)



Oil amount
27ℓ×2

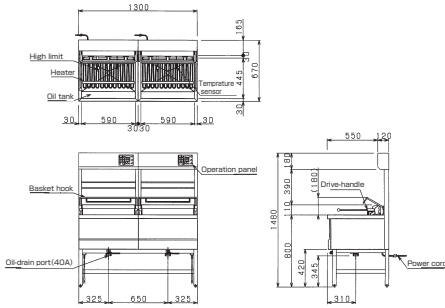

MEF-DLK18BUW

Table set type

List Price : ¥1,606,000
(tax-excluded)



Oil amount
18ℓ×2

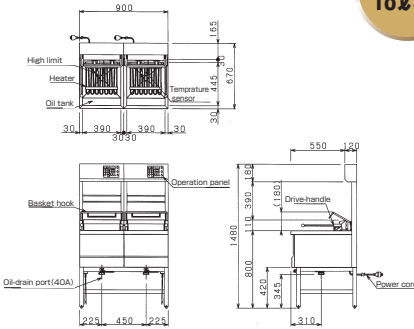

MEF-DLK23BUW

Table set type

List Price : ¥1,946,000
(tax-excluded)



Oil amount
23ℓ×2

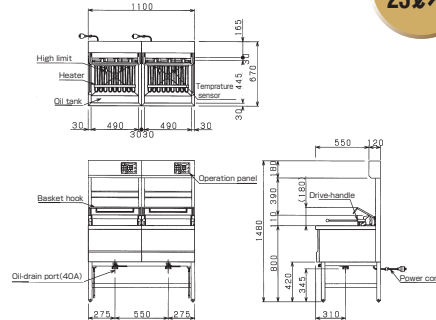

Electric Fryer for Delicatessen <Auto Lift type> Table set type Specification Table

■ It takes 3 weeks to be produced

Model	External dimension (mm)			Oil amount (ℓ)	Power (50/60Hz)	Power consumption (kW)	Necessary hand switch capacity	Power cord	Weight (kg)	Accessories							
	Width	Depth	height							Cover	Partition net	Skimming net	Oil tank	Oil screen	Fried food basket	Fitting plate	
Control panel at front type	MEF-DLK18BW	900	735	800	18×2	3φ200V	11.8	20A×2(40A)	2m ground 3P 20A with hook plugⓈ×2	113	2	2	2	L2	2	2	1
	MEF-DLK23BW	1100	735	800	23×2	3φ200V	15.7	30A×2(60A)	2m ground 3P 30A with hook plugⓈ×2	127	2	2	2	S4	4	2	1
	MEF-DLK27BW	1300	735	800	27×2	3φ200V	19.6	40A×2(75A)	2m 8mm ² -4 core direct connecting×2	137	2	2	2	S4	4	2	1
Control panel at left and right separated type	MEF-DLK18BSW	900 (1240)	735	800 (1450)	18×2	3φ200V	11.8	20A×2(40A)	2m ground 3P 20A with hook plugⓈ×2	119	2	2	2	L2	2	2	1
	MEF-DLK23BSW	1100 (1440)	735	800 (1450)	23×2	3φ200V	15.7	30A×2(60A)	2m ground 3P 30A with hook plugⓈ×2	133	2	2	2	S4	4	2	1
	MEF-DLK27BSW	1300 (1640)	735	800 (1450)	27×2	3φ200V	19.6	40A×2(75A)	2m 8mm ² -4 core direct connecting×2	143	2	2	2	S4	4	2	1
Control panel at upper part type	MEF-DLK18BUW	900	670	1480	18×2	3φ200V	11.8	20A×2(40A)	2m ground 3P 20A with hook plugⓈ×2	113	2	2	2	L2	2	2	1
	MEF-DLK23BUW	1100	670	1480	23×2	3φ200V	15.7	30A×2(60A)	2m ground 3P 30A with hook plugⓈ×2	127	2	2	2	S4	4	2	1
	MEF-DLK27BUW	1300	670	1480	27×2	3φ200V	19.6	40A×2(75A)	2m 8mm ² -4 core direct connecting×2	137	2	2	2	S4	4	2	1

* Dimensions in () include the operating unit.

Accessories

- Cover
- Skimming net
- Oil tank
- Oil screen
- Partition net
- Fried food basket
- Fitting plate

Options for Front Panel type and Left and Right Separated type

- Oil drain plate set that is put at upper position.
- Fry Basket Holder

Options for Upper Part type

- Oil drain plate set that is put at upper position.
- Fry Basket Holder (Control panel at upper part type)

* There may have different sizes and specs depending on the model.

Non-Auto Lift type is also available!

MEF-D

Control panel at front type

MEF-D18B

List Price : ¥485,000
(tax-excluded)



Oil amount
18ℓ

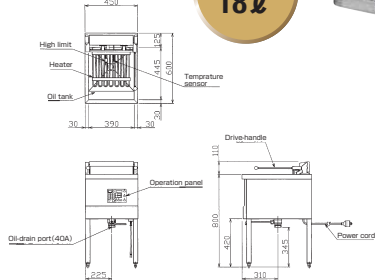

MEF-D23B

List Price : ¥580,000
(tax-excluded)



Oil amount
23ℓ

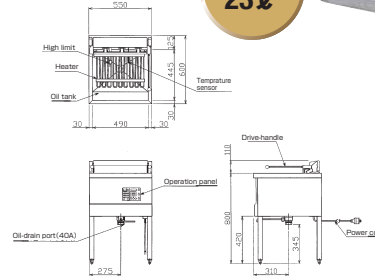

MEF-D27B

List Price : ¥654,000
(tax-excluded)



Oil amount
27ℓ

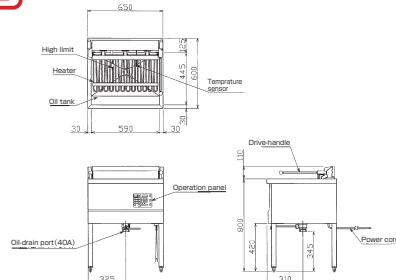

Control panel at left and right separated type

MEF-D18BL(R)

List Price : ¥565,000
(tax-excluded)



Oil amount
18ℓ

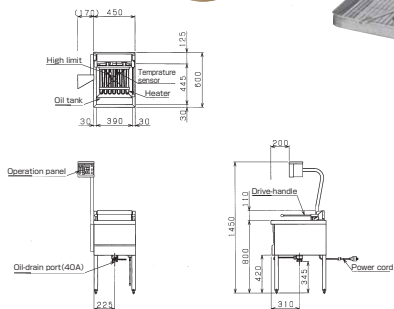

※ This picture is for control panel on left side type

MEF-D23BL(R)

List Price : ¥697,000
(tax-excluded)



Oil amount
23ℓ

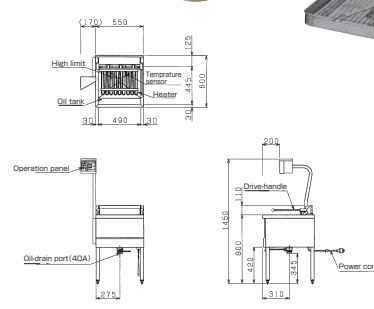

※ This picture is for control panel on left side type

MEF-D27BL(R)

List Price : ¥734,000
(tax-excluded)



Oil amount
27ℓ

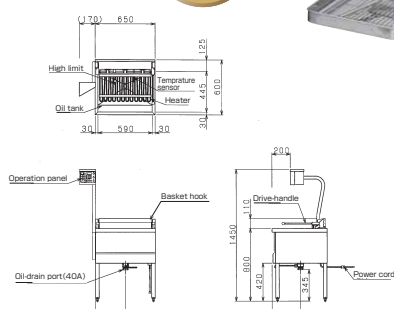

※ This picture is for control panel on left side type

R in the end of model name means control panel on right side type.

MEF-D27BR

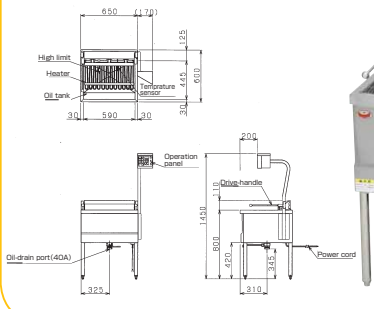

Electric Fryer for Delicatessen

■ It takes 2 weeks to be produced

Model	External dimension (mm)			Oil amount (ℓ)	Power (50/60Hz)	Power consumption (kW)	Necessary hand switch capacity	Power cord	Weight (kg)	Accessories								
	Width	Depth	height							Cover	Partition net	Skimming net	Oil tank	Oil screen	Oil drain plate	Oil drain net	Sliding plate	
Control panel at front type	MEF-D18B	450	600	800	18	3φ200V	5.85	20A	2m ground 3P 20A with hook plug	43	1	1	1	L1	1	1	1	1
	MEF-D23B	550	600	800	23	3φ200V	7.8	30A	2m ground 3P 30A with hook plug	48	1	1	1	S2	2	1	1	1
	MEF-D27B	650	600	800	27	3φ200V	9.75	40A	2m 8mm ² -4 core direct connecting	52	1	1	1	S2	2	1	1	1
Control panel at left and right separated type	MEF-D18BL (R)	450 (620)	600	800 (1450)	18	3φ200V	5.85	20A	2m ground 3P 20A with hook plug	46	1	1	1	L1	1	1	1	1
	MEF-D23BL (R)	550 (720)	600	800 (1450)	23	3φ200V	7.8	30A	2m ground 3P 30A with hook plug	51	1	1	1	S2	2	1	1	1
	MEF-D27BL (R)	650 (820)	600	800 (1450)	27	3φ200V	9.75	40A	2m 8mm ² -4 core direct connecting	55	1	1	1	S2	2	1	1	1

※ Dimensions in () include the operating unit.

Accessories

- Sliding plate
- Cover
- Oil tank
- Oil screen
- Skimming net
- Oil drain net
- Oil drain plate
- Partition net

※ There may have different sizes and specs depending on the model.

Options for Upper Part type

- Sliding plate for tempura
- Partition net for tempura
- Oil drain plate set that is put at upper position.
- Fried food basket
- Fitting plate

Easy Cleaning Table set type is available!!

Electric Fryer for Delicatessen

Control panel at front type

Table set type

MEF-DK27BW

Table set type

List Price : ¥1,338,000 (tax-excluded)



Oil amount 27ℓ×2

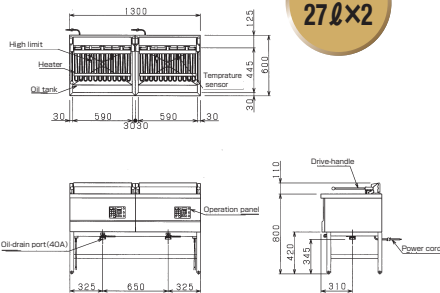

MEF-DK18BW

Table set type

List Price : ¥1,000,000 (tax-excluded)



Oil amount 18ℓ×2

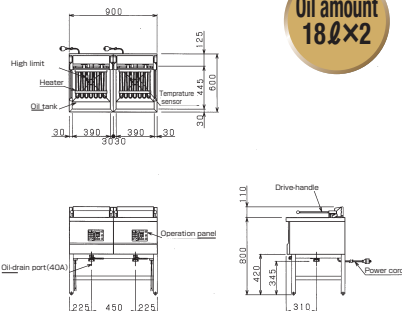

MEF-DK23BW

Table set type

List Price : ¥1,190,000 (tax-excluded)



Oil amount 23ℓ×2

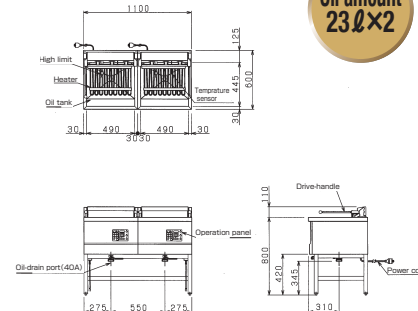

MEF-DK27BSW



Table set type

List Price : ¥1,498,000
(tax-excluded)

Oil amount
27ℓ×2

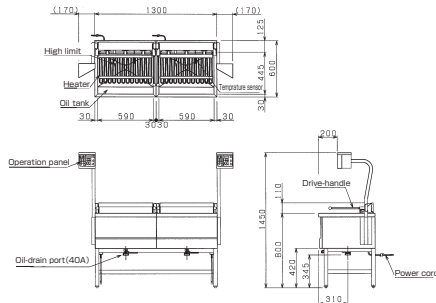

MEF-DK18BSW



Table set type

List Price : ¥1,160,000
(tax-excluded)

Oil amount
18ℓ×2

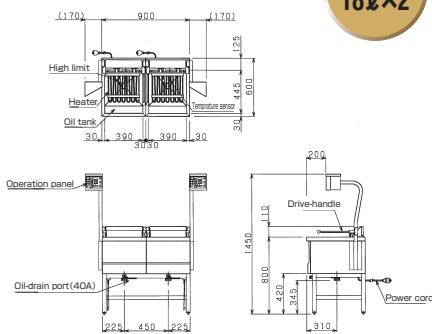

MEF-DK23BSW



Table set type

List Price : ¥1,424,000
(tax-excluded)

Oil amount
23ℓ×2

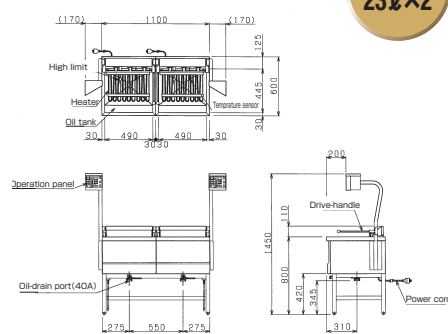

Electric Fryer for Delicatessen Table set type Specification Table

■ It takes 3 weeks to be produced

Model	External dimension (mm)			Oil amount (ℓ)	Power (50/60Hz)	Power consumption (kW)	Necessary hand switch capacity	Power cord	Weight (kg)	Accessories									
	Width	Depth	height							Cover	Partition net	Skimming net	Oil tank	Oil screen	Oil drain plate	Oil drain net	Sliding plate	Fitting plate	
Control panel at front type	MEF-DK18BW	900	600	800	18×2	3φ200V	11.7	20A×2(40A)	2m ground 3P 20A with hook plugⓈ×2	89	2	2	2	L2	2	2	2	2	1
	MEF-DK23BW	1100	600	800	23×2	3φ200V	15.6	30A×2(60A)	2m ground 3P 30A with hook plugⓈ×2	99	2	2	2	S4	4	2	2	2	1
	MEF-DK27BW	1300	600	800	27×2	3φ200V	19.5	40A×2(75A)	2m 8mm ² -4 core direct connecting×2	107	2	2	2	S4	4	2	2	2	1
Control panel at left and right separated type	MEF-DK18BSW	900 (1240)	600	800 (1450)	18×2	3φ200V	11.7	20A×2(40A)	2m ground 3P 20A with hook plugⓈ×2	95	2	2	2	L2	2	2	2	2	1
	MEF-DK23BSW	1100 (1440)	600	800 (1450)	23×2	3φ200V	15.6	30A×2(60A)	2m ground 3P 30A with hook plugⓈ×2	105	2	2	2	S4	4	2	2	2	1
	MEF-DK27BSW	1300 (1640)	600	800 (1450)	27×2	3φ200V	19.5	40A×2(75A)	2m 8mm ² -4 core direct connecting×2	113	2	2	2	S4	4	2	2	2	1

※ Dimensions in () include the operating unit.

Accessories

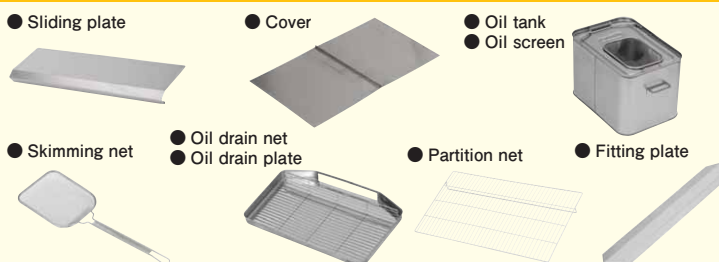

※ There may have different sizes and specs depending on the model.

Options for Upper Part type

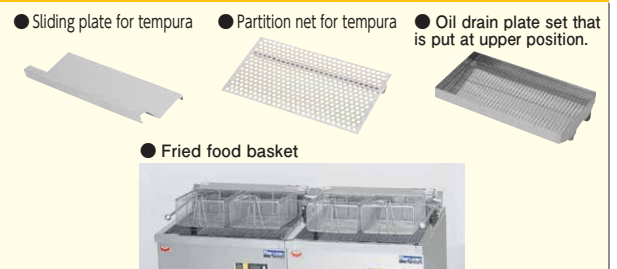

Optimized to cook Tempura and space-saved oil tank structure reduce oil amount and electric consumption dramatically!

Oil-saving & Energy-saving realize low running cost!

Oil amount is reduced 33%!

Cool zone which keeps fried scraps is not necessary for frying Tempura. Since fried scraps do not precipitate much when frying Tempura. Therefore, Oil amount is reduced 33% comparing with "Electric Fryer for Delicatessen" which has the same oil tank area. The cost of oil can be reduced drastically.

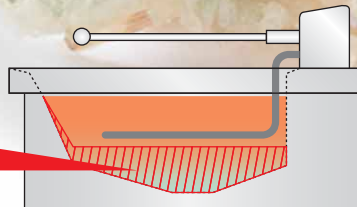

This space is cut!

Electric consumption is reduced around 30%!

Output of Heater for heating oil is saved in accordance with the reduced oil amount. Output of heater is reduced 30% comparing with "Electric Fryer for Delicatessen" which has the same size of oil tank area. The cost of electricity can be reduced drastically.

More compact of heating zone realizes oil-saving!

The shape of heater is thinner and simpler because of reducing electric consumption. Heating zone is more compact which realize reducing oil amount even more. Also, it is easy to clean.



Excellent safety is realized by "slow down function"!

When you lift down the heater back to the original position, it will not fall down quickly but slowly goes down. It can prevent the heater fall down to oil, and you don't have to worry about your skin burn. Moreover, lifted heater stops energization automatically, which drastically reduce the dangerousness of skin burn. The safety when you clean up is drastically improved.



Temperature of oil and frying time can be set!

The oil temperature (Between 100 to 220°C) and frying time (Timer: Between 0 sec to 99 min 59 sec) can be set in advance (Max.99 menus). Also, frying time can be changed temporarily by manual switch. The melody for finish cooking can be chosen from 7 patterns. Therefore, even if using several units, the melody can be different for each equipment, which is very useful for recognition when finish frying.

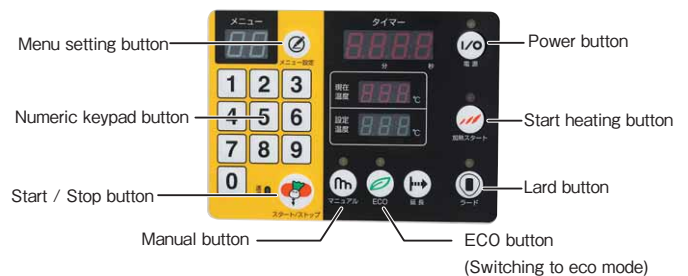

Deliciously fried with extreme-infrared effect.

Extreme-infrared radiation from the heater heats evenly. This also suppresses the deterioration of the oil and achieves delicious cooking without missing the flavor of the food.



Eco mode realizes energy saving reducing the oil oxidized

Right after pushing ECO button, it is switched to eco mode which keeps the oil temperature lower than the set temperature. That realizes not only preventing oil oxidized but also energy saving. Also, setting is available to switch to eco mode automatically when constant time passes over without cooking. Please contact us for details.

Useful "Melt Function" to use the solid oil. (Lard heating)

Melt function (lard heating) to gradually dissolve solid oil is equipped. It is very useful when you use solid oil such as lard.

Electric Tempura Fryer is offered with a type that conforms to the specification of the description of the Minister of Land, Infrastructure and Transport Secretariat Government Buildings Department supervision "public building construction standard specifications" (machine knitting equipment work).

Excellent for cleaning and safety

Flatted oil tank is excellent for cleaning!

Changing oil and cleaning oil tank can be done easily by swing up heater. In side of oil tank is totally flat and easy to clean. Moreover, the shape of heater is simple, so it is easy to clean even more.



Foldable cover can be put under the body.

Cover of oil tank is foldable and can be put under the body. You don't need to concern about the place for putting it.



Perfect for floor cleaning

Leg part of main body is round pipe which makes cleaning easier. Moreover, there is a wide space under the equipment, so you can use cleaning tools like mops easily, which is perfect for floor cleaning.



Overheating prevention device is equipped and safe

The overheating prevention device is equipped, which automatically and safely stops heating in case oil temperature rises abnormally.



Electric Tempura Fryer

MEF-T18B

List Price : ¥465,000
(tax-excluded)



Oil amount
12ℓ

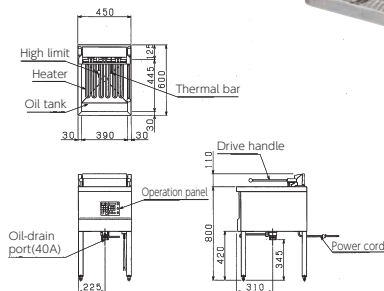

MEF-T27B

List Price : ¥634,000
(tax-excluded)



Oil amount
18ℓ

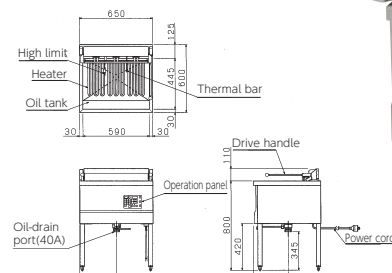

Electric Tempura Fryer specification table

■ The delivery time is about 2 weeks after a receipt of order.

Model	External dimension(mm)			Oil amount (ℓ)	Power (50/60Hz)	Power consumption (kW)	Necessary hand switch capacity	Power cord 2m	Weight (kg)	Accessories
	Width	Depth	height							
MEF-T18B	450	600	800	12	3φ200V	4.2	15A	2mm ² -4core direct connecting	43	Cover, Partition net for tempura, Skimming net, Oil tank(L), Oil screen, Oil drain plate, Oil drain net, Sliding plate for tempura
MEF-T27B	650	600	800	18	3φ200V	7.0	30A	ground 3P 30A with hook plug	55	Cover, Partition net for tempura, Skimming net, Oil tank(L), Oil screen, Oil drain plate, Oil drain net, Sliding plate for tempura

Accessories

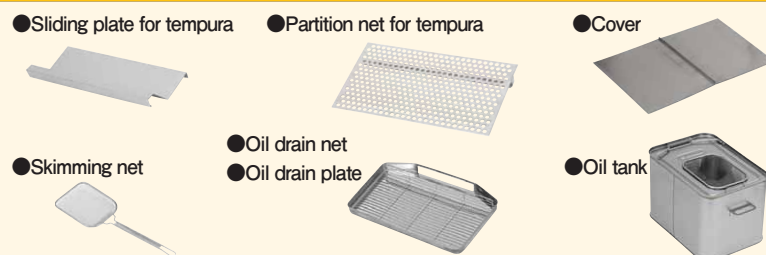

Options

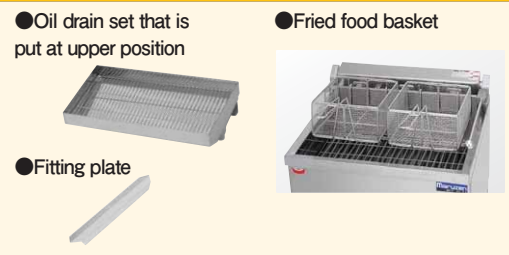

※There may have different sizes and specs depending on the model.

Electric double auto-lift fryer

Electric double auto-lift fryer with two fry baskets! Best use for various kinds and small quantity cooking!

It is possible to cook different menu at the same time by one person, using two fry baskets equipped with auto-lift mechanism.

Helpful for lack of staff in the kitchen!

It is effective for labor-saving since the fry baskets automatically lift up when the set cooking time comes. Different menu can be cooked at the same time because the cooking time can be set separately by each operation panel, which can make work efficiency further improved. Electric sound informs you the end of cooking comes close, and melody informs you the end of cooking. You won't miss the best timing of freshly-fried. Also, you can extend the cooking every 10 seconds by one-touch operation.



Each left and right fry baskets are lifted up individually.

Safety by slow down function! Swung up heater turns off electricity automatically!

When you lift down the heater back to the original position, it will not fall down quickly but slowly goes down. It can prevent the heater fall down to oil, and you don't have to worry about your skin burn. Moreover, lifted heater stops energization automatically, which drastically reduce the dangerousness of skin burn. The safety when you clean up is drastically improved. (Except Tabletop type)



Eco mode realizes energy saving reducing the oil oxidized



Right after pushing ECO button, it is switched to eco mode which keeps the oil temperature lower than the set temperature. That realizes not only preventing oil oxidized but also energy saving. Also, setting is available to switch to eco mode automatically when constant time passes over without cooking. Please contact us for details.

Foldable cover can be put under the body.

Cover of oil tank is foldable and can be put under the body. You don't need to concern about the place for putting it. (Except for table top type)



99 menus can be registered! "Double Frying" can be programmed!

Cooking program can be registered up to 99 menus. Not only the oil temperature (Between 100 to 220°C) and cooking time (Between 0 sec to 99 min 59 sec), but also step cooking such as "Double Frying" can be programmed in advance. Your original taste and labor saving can be realized at the same time. Melody for the end of cooking can be chosen from 7 patterns. Therefore, it can be easier to recognize the end of cooking by changing melodies of left and right fry baskets.



The operation panel at left side has a switch of menu setting, start/stop and extension only.

The depth of stand type is 600mm! *The industry's first!* Wide range of cooking is possible in limited space!

We realize "depth 600mm" for stand type auto-lift fryer as the industry's first. It can be replaced with standard size fryer that does not have auto-lift, which is not only expand the choice of installation place but also realize various kinds and small quantity cooking in a limited space in kitchen by double auto-lift.

Useful "Melt Function" to use the solid oil. (Lard heating)

Melt function (lard heating) to gradually dissolve solid oil is equipped. It is very useful when you use solid oil such as lard.

Electric double auto-lift fryer is offered with a type that conforms to the specification of the description of the Minister of Land, Infrastructure and Transport Secretariat Government Buildings Department supervision "public building construction standard specifications" (machine equipment work).

Easy cleaning with swing-up method cartridge heater

You can swing up the heater, making it easy to clean and replace the oil. Cartridge heater is simple shape which is easy to be cleaned.



Perfect for floor cleaning

Leg part of main body is round pipe which makes cleaning easier. Moreover, there is a wide space under the equipment, so you can use cleaning tools like mops easily, which is perfect for floor cleaning. (Except for table top type)



Overheating prevention device is equipped and safe

The overheating prevention device is equipped, which automatically and safely stops heating in case oil temperature rises abnormally.

Electric double auto-lift fryer

Tabletop type

MEF-WL13TB

List Price : ¥690,000 (tax-excluded)



Oil amount
13ℓ

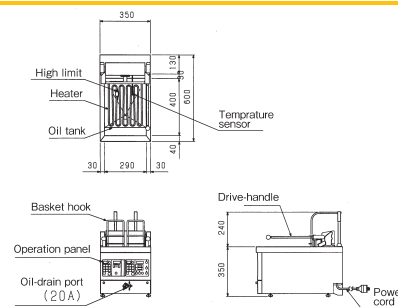

Regular type -1-tank

MEF-WL13B

List Price : ¥830,000 (tax-excluded)



Oil amount
13ℓ

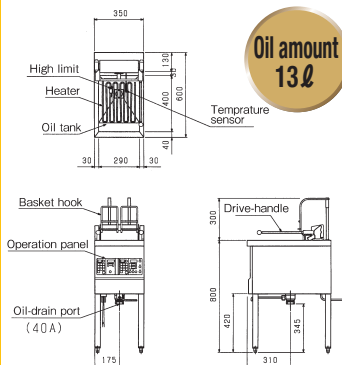

MEF-WL18B

List Price : ¥888,000 (tax-excluded)



Oil amount
18ℓ

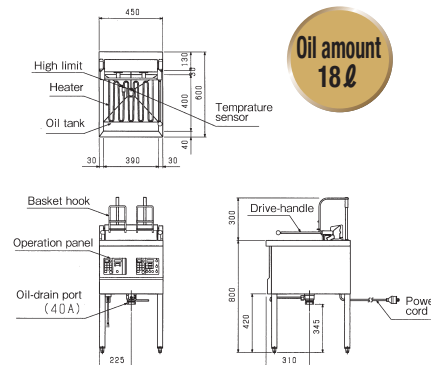

Electric double auto-lift fryer specification table

■ It takes 2 weeks to be produced

Model	External dimension (mm)			Oil amount (ℓ)	Power (50/60Hz)	Power consumption (kW)	Necessary hand switch capacity	Power cord 2m	Weight (kg)	Accessories
	Width	Depth	Height							
MEF-WL13TB	350	600	350	13	3φ200V	4.8	20A	ground 3P 20A with hook plug	36	Cover(1), Partition net(1), Skimming net(1), Fried food basket(2), Oil drain support(1), Oil drain tray(1)
MEF-WL13B	350	600	800	13	3φ200V	4.8	20A	ground 3P 20A with hook plug	46	Cover(1), Partition net(1), Skimming net(1), Oil tank(S1), Oil screen(1), Fried food basket(2)
MEF-WL18B	450	600	800	18	3φ200V	5.9	20A	ground 3P 20A with hook plug	52	Cover(1), Partition net(1), Skimming net(1), Oil tank(L1), Oil screen(1), Fried food basket(2)

Accessories

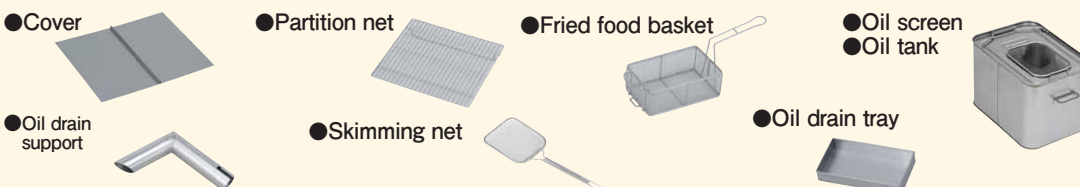

Option

● Fitting plate



※ There may have different sizes and specs depending on the model.

Reduce oil expense by lasting oil long! Keep fried food in good condition and it is essential for cooking fried food.



Save the cost, and keep the commercial value!

By filtering used oil, reduce contamination and the oil last long. Oil expense is reduced, and the fried food are beautiful and tasty. It is essential for cooking fried food

① Croquette without oil filter



② Croquette WITH oil filter



Appearance and commercial value are kept by keeping beautiful frying!

- ※6 hours per day x 9 days
- ※① Remove fried oil debris once per day.
- ※② Oil filter once per day.
- ※ It depends on the using condition.

Safe and efficient for filling oil and cleaning oil tank.

Drain used oil to oil filter and turn the power on, filtered oil come out from the hose and return to the oil tank. It is not necessary to put up heavy oil tank, safety have improved. Also, by flowing filtered oil into the tank, it is efficient to clean fried debris and so on in the tank.

The material of drain hose is accepted by Food Hygiene Law!

Drain Hose is used by the material which Food Hygiene Law accepts in Japan. Oil resistant and heat resistant, it is a relief.

Only Maruzen adopts the material which Food Hygiene Law accepts in Japan.



Magnet is attached to stable hose.
※Please hold handle when in discharge.

POINT

- It is a compact design which can store under the fryer.
- By Debris Catch Net and Filter Paper, it can remove small fried debris and contamination perfectly.
- Change of filter paper is simple, and cleaning of oil tank is easy.



Example of installation with Electric Fryer for Delicatessen.
(Please contact us for suitable model)

Oil Filter

MOF-20

List Price : ¥198,000
(tax-excluded)

Oil amount
20 ℓ

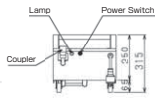
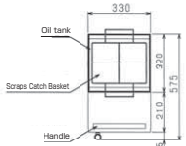

Power cord



MOF-27

List Price : ¥210,000
(tax-excluded)

Oil amount
27 ℓ

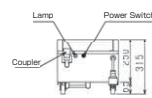
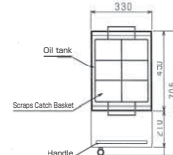

Power cord



MOF-40

List Price : ¥268,000
(tax-excluded)

Oil amount
40 ℓ

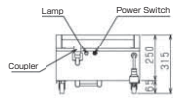
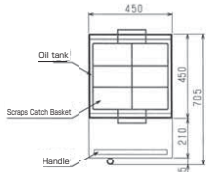

Power cord



Suitable combination for models between fryer and oil filter, please contact us.

Accessories

- Filter Paper (10 sheets)

time to change:
Everyday*



- Filter cloth (1 sheet)

time to change:
once in 6 month*



- Extension Cord



(Selling separately) 50 sheets
For MOF-20/¥4,300 (tax-excluded)
For MOF-27/¥5,000 (tax-excluded)
For MOF-40/¥5,700 (tax-excluded)

(Selling separately) 2 sheets
For MOF-20/¥5,000 (tax-excluded)
For MOF-27/¥5,700 (tax-excluded)
For MOF-40/¥7,600 (tax-excluded)

* it might be different depending on how to use

Option



- mir oil filter
¥19,000 (tax-excluded)

When it is set

Used for filtering tinier fried scraps.

Oil filter Specification Table

Model	Dimension (mm)			Oil amount	Filtering capacity (ℓ / m) (50/60Hz)	Filtering Temperature (°C)	Power (50/60Hz)	Power consumption (W)	Power cord	Weight (kg)	Accessories
	Width	Depth	height								
MOF-20	330	575	315	20	6/5.5	80~150	1 φ 100V	150	3m with plug (ground adapter) ⚡	25	Filter Paper, Filter cloth, Extension Cord
MOF-27	330	705	315	27	6/5.5	80~150	1 φ 100V	150	3m with plug (ground adapter) ⚡	30	Filter Paper, Filter cloth, Extension Cord
MOF-40	450	705	315	40	6/5.5	80~150	1 φ 100V	150	3m with plug (ground adapter) ⚡	34	Filter Paper, Filter cloth, Extension Cord

■ This product cannot be used for solid oil

Proofer and fryer in one! Perfect for favorite Menu such as doughnut and curry bread.

Proofer and fryer come together You can work efficiently.

It is a dedicated model that combines a proven fryer at the top and a sophisticated proofer at the bottom. Dough will be fried in the fryer immediately after fermentation, contributing to enhancing the work efficiency. Without taking the space with one unit, you can start immediately the baking for popular menu, such as curry bread and doughnut.

Safety by slow down function! Swung up heater turns off electricity automatically!

When you lift down the heater back to the original position, it will not fall down quickly but slowly goes down. It can prevent the heater fall down to oil, and you don't have to worry about your skin burn. Moreover, lifted heater stops energization automatically, which drastically reduce the dangerousness of skin burn. The safety when you clean up is drastically improved.



An infrared sheathed heater is adopted with good thermal efficiency.

This heater is compact and can fry a lot of doughnuts at a time.



Compact proofer with high functionality.

Proofer is equipped with a simple humidifier, resulting in the ideal fermentation, keeping the uniform temperature and humidity inside. A water level sensor is equipped in the simple humidifier. This sensor will inform the reduction on water quantity by lighting up a lamp.

In addition, a LED is equipped inside the Proofer which you can see the fermentation state of the dough in every detail.



Fitting plate (option) is available.

Fitting plate can be used when using R-type and L-type of doughnut fryer system side-by-side. This maintains hygiene while preventing the entrance of water, oil or dust between the system bodies.

Easy to clean up with the swing-up type heater.

It is possible to swing up the heater unit, and easy for cleaning the oil tank. Furthermore, cleaning has been upgraded by performing R processing in the corner of the oil tank.



Manage oil temperature in a microcomputer control.

Oil temperature of the fryer can be controlled in units of 1 °C between 100 to 220°C by the microcomputer control. Simple dial-up proofer has been adopted. The operating state can always be confirmed from the window even when the operation unit cover for preventing the entrance of oil is in the closed state. The oil temperature can also be seen in the digital display.



Picture shows the opened cover.

Useful "Melt Function" to use the solid oil. (Lard heating)

Melt function (lard heating) to gradually dissolve solid oil is equipped. It is very useful when you use solid oil such as lard.



Safe with overheating prevention mechanism.

It has an overheating prevention mechanism including a high limit switch to cut off the circuit automatically when the oil temperature rises abnormally. Furthermore, it is more secure because it cuts off the circuit even when the abnormality occurs in the high limit body.



Side rack easy for use.

The sliding is installed at the top plate of the side rack. With the sliding shape, drained oil can be back to the oil tank of the fryer. It also contributes to cost savings as well as clean-ability.

A net supporter of each step can be removed, so you can clean it easily. The moving can be easy with a caster. As shown in the pictures below, oil draining is done after removing the side rack.



Doughnut fryer is compatible with the specification described in "public building construction standard specifications" of the Minister of Land, Infrastructure and Transport Secretariat Government Buildings Department supervision (machine knitting equipment work).

Doughnut fryer system

MEFD-18GL + MEFD-18RCL

List Price : ¥635,000
(tax-excluded)



Oil amount
18ℓ

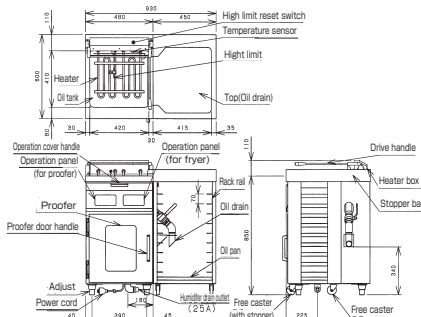

MEFD-18GL

List Price : ¥590,000
(tax-excluded)

MEFD-18RCL

List Price : ¥45,000
(tax-excluded)



MEFD-23GL + MEFD-23RCL

List Price : ¥730,000
(tax-excluded)



Oil amount
23ℓ

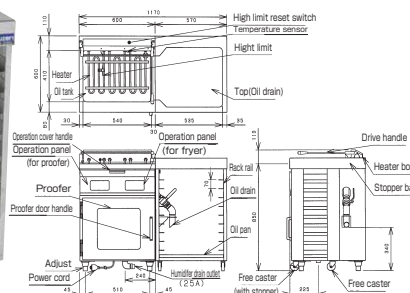

MEFD-23GL

List Price : ¥680,000
(tax-excluded)

MEFD-23RCL

List Price : ¥50,000
(tax-excluded)

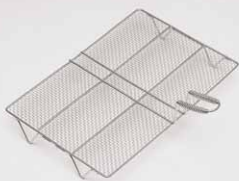
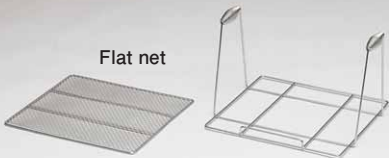

Option	Accessories
 doughnut holding net	 Flat net Flat Net Receiver

There may have different sizes and specs depending on the model.



Doughnut fryer system Specification Table

Model	External dimension (mm)			Oil amount (ℓ)	Power (50/60Hz)	Power consumption (kW)	Necessary hand switch capacity	Power cord	Drain outlet	Weight (kg)	Accessories
	Width	Depth	Height								
☆MEFD-18GL (R)	480	600	850	18	3 φ 200V	3.95	20A	2m ground 3P 20A with hook plug	25A	53.5	Cover, Oil tank (large), Oil filtering net, Flat net×5, Flat net receiver
☆MEFD-18RCL (R)	450	600	895	—	—	—	—	—	—	20.5	—
MEFD-23GL (R)	600	600	850	23	3 φ 200V	5.75	20A	2m ground 3P 20A with hook plug	25A	59.5	Cover, Oil tank (large), Oil filtering net, Flat net×5, Flat net receiver
☆MEFD-23RCL (R)	570	600	895	—	—	—	—	—	—	22	—

■ Last number of model means that Doughnut fryer body is placed on the left, R is the right place.
 ■ Delivery time of ☆ marked model and MEFD-23GR is about 2 weeks after placing order.

Next-generation ideal Fryer!

- High fried capacity with a minimum amount of oil.
- High cooking ability can be realized.
- Low running cost low output of industry No.1.
- To firmly ensure the cool zone. Oil lasts a long time.
- No any kind of parts in tank. Excellent cleaning!
- No worries about heater burns. Improved Safety!



Nothing in the tank with excellent clean-ability.

High cooking capacity

Maximum fried capacity can be performed with the minimum amount of oil compared with other fryers of the same size.

For that there are no parts in oil tank, you can fry a lot of ingredients with less oil. The amount of oil per cooking area is 7 liters of industry's smallest!

Startup and recovery operation can be performed quickly.

Convenient melt function (Lard heating) to use the solid oil.

In case of using the solid oil such as lard, the melt function (lard heating) to gradually dissolve solid oil is convenient.

Please contact us at the time of the purchase about use of the melt function.

Low running cost

Small amount of oil and low output of industry No.1!

Thanks to heating method of the high thermal efficiency and reduction on the amount of oil, low output of industry No.1 was realized. Power consumption is lower by far compared with a fryer which has equivalent cooking capacity. It will lead to a reduction in utility costs. In addition, since the amount of oil is less, waste oil disposal costs and oil bill can be reduced.

Furthermore running cost is cut by setting the output according to the stores.

Normal output of the IH tabletop fryer is 3kW, but it is also possible to use a lower output according to sales operation type of customers, menu and frequency of use. Please inquire at the time of the purchase.

Excellent cleaning

Excellent cleaning!

For that there are no any kinds of parts inside the tank, cleaning is perfectly performed. Cleaning work after the end of cooking can be significantly reduced, leading to a reduction in labor costs.

You can choose the downward oil drain or forward oil drain.

Downward oil drain can easily and securely be done the waste oil by using the dedicated stand together.

Forward oil drain can be performed easily by attaching an oil drain hose with a single touch.

Cooking can be performed in manual by simple operation.

You can easily use a simple design operation panel. The oil temperature can be set in units of 1 °C between 30 to 220°C by microcomputer control. Since the temperature and cooking time (Between 0 sec to 99 min 59 sec) can be registered up to 10 menus, labor savings is realized and cooking process can be manualized. A buzzer alarms at the end of cooking.

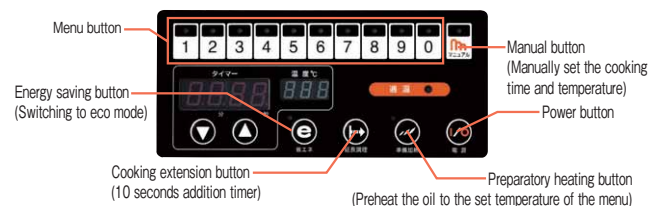

Oil lasts a long time

Oil lasts a long time by the cool zone of Maruzen's dedication.

The oil is heated evenly and uniformly by heat convection that is generated from the oil tank bottom. Since fried oil debris and water residue fall in the cool zone, the life of oil lasts by suppressing oxidation, saving the oil cost.

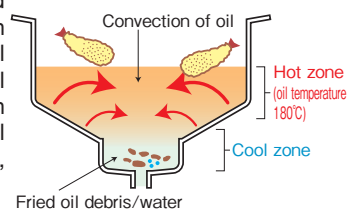

Further energy saving in eco mode. Oil lasts.



If no cooking time pasts during a certain period of time, the oil temperature will be in eco mode for setting the oil temperature to 20 degrees lower than the set temperature. The eco mode will suppress the oxidation of the oil, leading to not only extension of oil usage period, but also power consumption saving. Eco mode can also be switched manually by pressing the energy saving mode button.

Safety

Risk of burns is greatly reduced!

Since there is no heater, you do not need to worry about an accidental touch on the heater that was flipped and falling of heater into the oil surface.

Expansion of the safety device.

A high limit for preventing overheating of the oil is adopted. And protection function, which stops the operation even if it detects temperature rise and an electrical abnormality in the main body, is adopted. It Further enhances the safety.

IH round type fryer

Great for demonstration! Adequate big diameter round type fryer for “Demonstration kitchen”!!



These days, “Demonstration kitchen” is popular among food service industry. It is a kitchen trend to appeal customers cooking and create the feeling of being at a live. It can appeal customers fresh-cooked.

“Maruzen” IH round type fryer is round shape and appeal the line of the pot. Installing in front of customers over the counter, **it has a demonstration effect to appeal customers as if cooking by big special pot**. It can appeal “fresh-cooked” very much. This is the perfect fryer for “Demonstration kitchen”.



Back guard height is kept low in order not to block customer's view.



Big amount of fried food can be cooked smoothly!

Movability and high cooking capacity are realized!

Oil tank shape is round, so that flipping of foods and catching frying scraps can be done smoothly. Besides, IH heating enable returning temperature soon after big amount of foods are thrown. Big amount of fried food can be cooked efficiently.



Simple and easy to use control panel

Control panel is very simple. Set temperature by Temperature set switch and push Start switch button. Oil temperature can be set in units of 1°C between 50 to 220°C by microcomputer control.



Low running cost!

Less amount of oil & high heat efficient IH heating method reduced the heating expenses!

Since there are no parts in the tank, oil amount can be less compared to the equivalent cooking area fryer. Besides, high efficient IH heating method lower electric consumption to 7kW and reduce heating expenses.

Oil last a long time!

Oil lasts a long time by the cool zone of Maruzen's dedication.

The oil is heated evenly and uniformly by heat convection that is generated from the oil tank bottom. Since fried scraps and water residue fall in the cool zone, the life of oil lasts by suppressing oxidation, saving the oil cost.

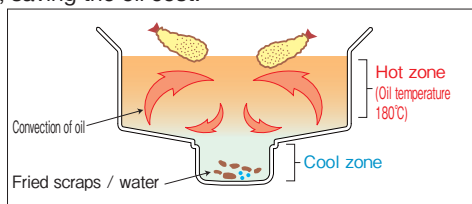

Further energy saving in eco mode, Oil lasts.

By pressing Energy saving button, it changes to eco mode which maintains temperature 20°C lower than set temperature. Eco mode suppresses the oxidation of oil, leading not only extension of oil usage period, but also power consumption saving.

Delicious frying without losing the aroma of fried food.

Cool zone and Eco mode enable oil last long with preventing oil oxidation. Fried food can be always cooked at clean Hot zone. So, delicious frying without losing the aroma of fried food is possible.

Safety!

Risk of burns is greatly reduced!

Since heater is not attached, heater won't be flipped and touched by anyone. Also, for the spot which can be easily touched by hand such as rail part, heat insulated structure is adapted, which dramatically reduce the danger of your skin burn.

Expansion of the safety device.

High limit for preventing oil overheating is adapted. And protection function which stops the operation when it detects temperature rise and an electrical abnormality in the main body, is adapted. It further enhances the safety.

Perfect for cleaning!

Easy to clean!

No parts are inside the tank, so it is perfect for cleaning. Besides, installed fried scraps receiver at tank bottom. Fried scraps is caught in the receiver, it is easy to throw away. Cleaning time after cooking is reduced. It can also lead to reducing personnel cost.



Perfect for cleaning nothing in the tank.



Fried debris is caught in the fried scraps receiver, it is easy to throw away.

IH round type fryer

MIF-500

List Price : ¥998,000
(tax-excluded)



Oil amount
18ℓ

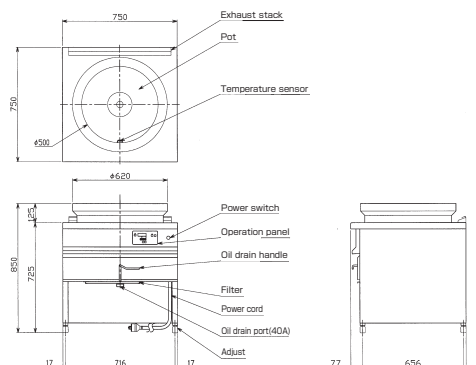

IH round type fryer Specification Table

Model	External dimension(mm)			Oil amount (ℓ)	Power (50/60Hz)	Power consumption (kW)	Necessary hand switch capacity	Power cord	Weight (kg)	Accessories
	Width	Depth	height							
MIF-500	750	750	725	18	3 φ 200V	7.0	30A	2m ground 3P 30A with hook plug 	77	Skimming net, Partition net, scrap receiver, Oil tank, Oil screen, Cover

Accessories

Please use according to the cooking menu.

● Partition plate for Tempura
(For Tempura)

● Partition net
(For other fried food)

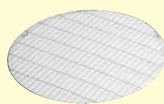
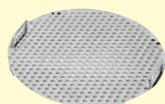

Scrap receiver



Oil tank



Oil screen

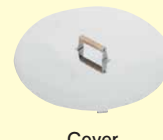

Cover

Heating pipe itself generates New IH heat! Advanced taste, economic and safety.

Model of IH fryer conforms to the specification of the description of the Minister of Land, Infrastructure and Transport Secretariat Government Buildings Department supervision "public building construction standard specifications" (machine equipment work).

Even and gentle heating with electromagnetic induction.

A new heating system is adopted in which an intermediate heating pipe itself is heated by electromagnetic induction of the heat coil.

Since a pipe is heated uniformly and evenly, it heats the oil efficiently. Further, to increase the surface area of the pipe can heat even a large amount of oil uniformly at once.



■ Heating pipe with a large surface area

Long-lasting oil with reducing oxidation and it is delicious.

Heating uniformity with "low temperature" by using the entire surface of the industry-leading heating pipe. Moreover, there is no localized overheating due to the large convection of oil generated in the tank, so it can save the oil cost by suppressing further oxidation of the oil. Fried oil debris, extra fry-batter and water content fall into the cool zone of oil tank bottom, so you can cook at a proper temperature part with less dirt, without missing the smell of deep-fried food.

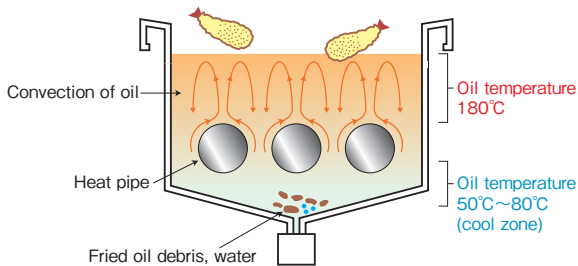

Cost saving, clean and safety.

Maruzen IH fryer achieves a high thermal efficiency that about 85 % or more of the power can be converted to heat. Since, in addition to the usage of energy without waste, there is no exhaust heat, it can save utility costs related to air conditioning such as cooling. In addition, the kitchen environment can be kept clean because oily smoke is less likely to occur thanks to low temperature uniform heating.

It can be cooked in manual by simple operation.

Temperature setting with 1 °C increments up to 100 ~ 220 °C is possible for all models by microcomputer control.

A control panel is visually easy with digital display for setting oil temperature and actually-measured oil temperature. It is possible to register the setting temperature of cooking oil up to 5 menus, so labor savings can be realized and cooking can be performed in manual.



Double safety design for emergency.

An overheating prevention device operating at the time of abnormal rise of oil temperature and a device for preventing heating without oil that operates in abnormal heating of the intermediate heating pipe due to the decrease in the amount of oil are provided.

The overheating prevention device is more secure because it operates even when the abnormality occurs in the high limit body.



Everyday cleaning easily.

An operation panel of the main body front is equipped with a cover which protects the operation part from dripping and splashing of oil.

In addition, it is a simple shape with only heating pipe in the tank, which makes you easy to clean all the parts of tank. Oil drain work is performed simply by just twisting the oil drain cock.

■ Cooking ability table (MIF-18C)

Cooking name	Cooked amount per once	Proper oil temperature	Cooking time	Capacity/h
Croquette (raw 50g)	15~21 pieces	180~200°C	2~3 minutes	250~350 pieces
Pork cutlet	16~20 pieces	180~190°C	2~4 minutes	200~250 pieces
Horse mackerel tempura	28~36 pieces	180~190°C	2~4 minutes	350~450 pieces
Vegetable tempura	12~31 pieces	160~180°C	1~3 minutes	200~500 pieces
French fries (frozen)	1.2kg	180°C	4 minutes	15kg
Fried chicken	1.2kg	180~190°C	3~6 minutes	10kg

*required time will be 30~50% increased in the case of frozen food.

Tabletop type -1-tank

MIF-11TC

List Price : ¥416,000 (tax-excluded)

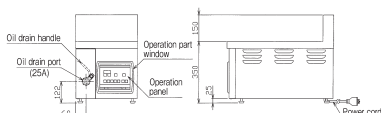
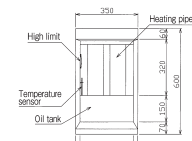

Oil amount 11ℓ

MIF-15TC

List Price : ¥426,000 (tax-excluded)

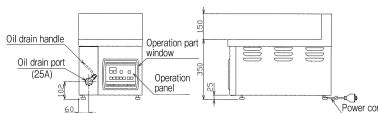
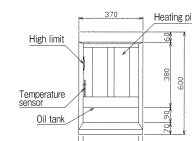

Oil amount 15ℓ

MIF-18C

List Price : ¥445,000 (tax-excluded)



Oil amount
18ℓ

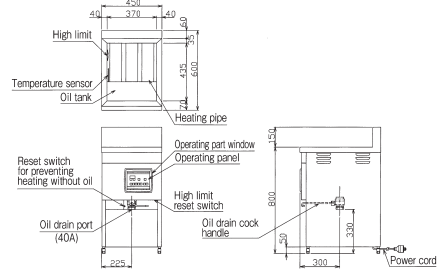

MIF-23C

List Price : ¥590,000 (tax-excluded)



Oil amount
23ℓ

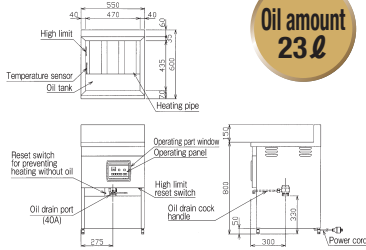

MIF-28C

List Price : ¥650,000 (tax-excluded)



Oil amount
28ℓ

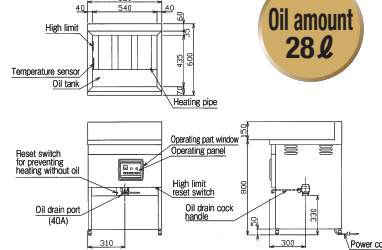

Regular type -2-tank

MIF-18WC

List Price : ¥880,000 (tax-excluded)

Oil amount
18ℓ×2

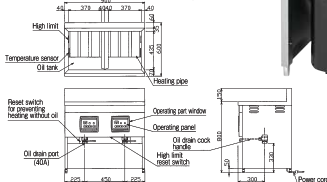

At the same time cooking of two types of deep-fried foods.

Fast Food type -1-tank

MIF-23FC

List Price : ¥630,000 (tax-excluded)

Oil amount
32ℓ

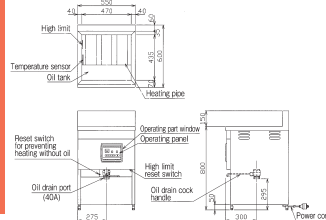

Oil tank is deeply suitable for selling on a large scale!

Low-frequency IH fryer Specifications Table

☆It is about 3 weeks for the delivery time after an order delivery model marked.

Model	External dimension (mm)				Oil amount (ℓ)	Power (50/60Hz)	Power consumption (kW)	Necessary hand switch capacity	Power cord	Weight (kg)	Accessories												
	Width	Depth	Height	Height back							Cover	Oil partition net	Skimming net	Oil tank	Oil screen	Oil drain plate	Oil drain net	Oil drain support pipe	Basket hook	Fried food basket			
Tabletop type	MIF-11TC	350	600	350	150	11	1φ200V	3.5	30A	2m ground 2P 30A with hooking plug	40	1	1	1				1	1	1			
	MIF-15TC	370	600	350	150	15	1φ200V	3.5	30A	2m ground 2P 30A with hooking plug	41	1	1	1				1	1	1			
Regular type	MIF-18C	450	600	800	150	18	3φ200V	5.3	30A	2m ground 3P 30A with hooking plug	68	1	1	1	L1	L1	1	1					
	MIF-23C	550	600	800	150	23	3φ200V	7.0	30A	2m ground 3P 30A with hooking plug	83	1	1	1	L1	L1	1	1					
	MIF-28C	620	600	800	150	28	3φ200V	8.5	40A	2m 8mm ² -4 core direct connecting	97	1	1	1	S2	S2	1	1					
	MIF-18WC	900	600	800	150	18×2	3φ200V	10.6	40A	2m 8mm ² -4 core direct connecting	135	1	2	2	L2	L2	2	2					
Fast Food type	☆MIF-23FC	550	600	800	150	32	3φ200V	7.0	30A	2m ground 3P 30A with hooking plug	87	1	1		L1	L1						1	3

Accessories

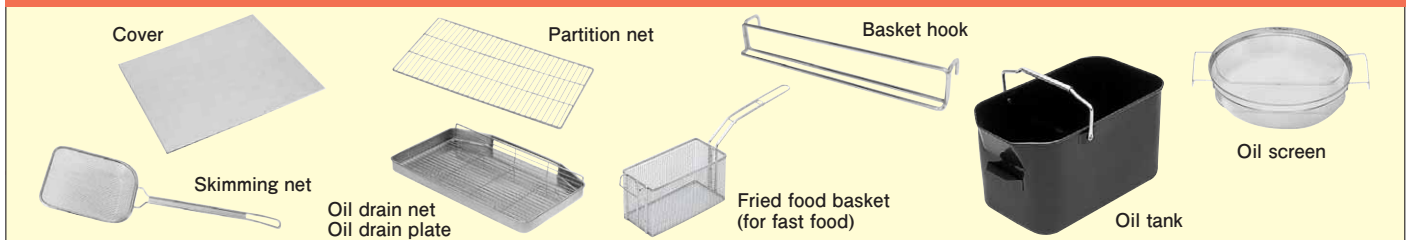

●There may have different sizes and specs depending on the model.

Low-frequency IH auto lift fryer

Lift up without missing a delicious fried time!

Subtle difference of fried condition is performed by simple operation.

World first
Auto lift function is normally provided into IH fryer!

Electromagnetic auto lift fryer is compatible with the specification of the description of the Minister of Land, Infrastructure and Transport Secretariat Government Buildings Department supervision "public building construction standard specifications" (machine facility work).

A part-time worker can also achieve the same fried condition as a veteran worker does.

A fry basket automatically can be lifted up with the preset cooking time. Even a part-time worker can perform fried cooking without mistaking fried time which is different for each menu, not only contributing to energy-saving, but also keeping a uniform taste. Subtle adjustment such as extension of cooking time during cooking and after cooking is also possible.



10 menus program function.

Up to 10 menus can be memorized for setting oil temperature (Between 100 to 220°C) and cooking time (Between 10 sec to 99 min 50 sec) according to your store's recipe.

Hot-selling menu and so on can be operated with a single touch just by pushing a menu button. A control panel of digital display is easy to read and accurate. It can be handled easily.



Save mode is economical to prevent the deterioration of the oil.

Save mode is switched in a state when the save switch is turned ON or in the case of non-use situation for 30 minutes. Keeping oil temperature to be 15 degrees lower than the preset temperature will prevent the deterioration of oil. It is economical.

Useful "Melt Function" to use the solid oil. (Lard heating)

Melt function (lard heating) to gradually dissolve solid oil is equipped. It is very useful when you use solid oil such as lard.

MIF-18LC

List Price : ¥668,000 (tax-excluded)



Oil amount 18ℓ

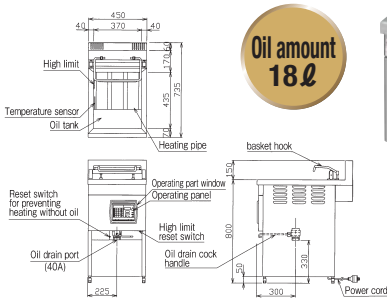

Up-and-down lift type

MIF-20SL

List Price : ¥748,000 (tax-excluded)



Oil amount 20ℓ

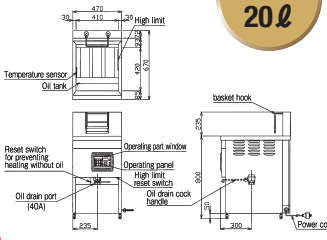

Since you can raise and lower the lift in a minimum of space, a fry basket can be enlarged up to the size of oil tank. Compared with other products of equivalent oil amount, you can cook a lot of ingredients at the same time. The depth is also compact with 670mm.

MIF-23LC

List Price : ¥828,000 (tax-excluded)



Oil amount 23ℓ

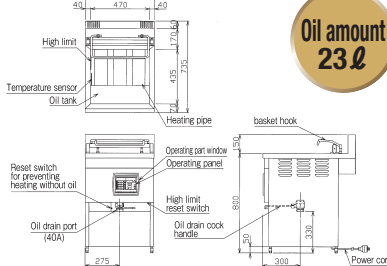

MIF-30LC

List Price : ¥898,000 (tax-excluded)



Oil amount 30ℓ

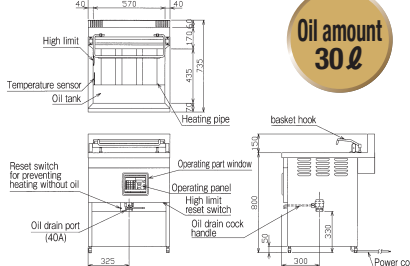

Low-frequency IH auto lift fryer Specifications Table

■The delivery time is about 3 weeks after receiving an order.

Model	External dimension (mm)			Oil amount (ℓ)	Power (50/60Hz)	Power consumption (kW)	Necessary hand switch capacity	Power cord	Weight (kg)	Accessories
	Width	Depth	Height							
MIF-18LC	450	735	800	18	3 φ 200V	5.4	30A	2m ground 3P 30A with hooking plug	84	Cover, Partition net, Skimming net, Oil tank (L1), Oil screen (L1), Fried food basket
MIF-23LC	550	735	800	23	3 φ 200V	7.1	30A	2m ground 3P 30A with hooking plug	97	Cover, Partition net, Skimming net, Oil tank (L1), Oil screen (L1), Fried food basket
MIF-30LC	650	735	800	30	3 φ 200V	8.6	40A	2m 8mm ² -4 core direct connecting	118	Cover, Partition net, Skimming net, Oil tank (S2), Oil screen (S2), Fried food basket
MIF-20SL	470	670	800	20	3 φ 200V	5.4	30A	2m ground 3P 30A with hooking plug	95	Cover, Partition net, Skimming net, Oil tank (L1), Oil screen (L1), Fried food basket

Accessories



●There may have different sizes and specs depending on the model.

While minimizing the deterioration of oil, change the fried cook of your store such as taste, cost, and environment significantly!

Taste improves thanks to ideal fried condition.

A fry saver forms an electric field in the oil tank. Thanks to the electric field, heat transfer enhancement effect (EHD effect) will efficiently fry the surface of ingredient, minimizing the outflow of component in ingredient. By reducing the combination between the flowed-out component in ingredient and oil, deterioration of the frying oil can be suppressed. For this reason, outside of food becomes crisp and the juicy taste is confined inside. Further, since oil absorption by fry coating can be reduced, so the taste appeals for healthy-oriented customers who are concerned about reducing calories and cholesterol.

Economical with reduced costs associated with oil.

A fry saver will shorten the frying time in addition to suppressing the deterioration of oil. The amount of oil usage is reduced, which will significantly reduce the cost of waste oil. In addition, The fry saver will realize yield ratio improvement for fried condition, productivity improvement, improvement of taste (quality), and synergy effect with the cost reduction and improved ability to attract customers. Therefore, it will contribute significantly to the economy of your store.

Environment of kitchen and In-store can also be improved by suppressing the deterioration of oil.

A fry saver is effective for improving the kitchen environment in addition to the reduction on waste oil. Oily smoke that occurs when frying foods is less, so it is comfortable for cooker, keeping an open kitchen clean.



Set a fry saver with MGF-18J

Cleaning and handling are also easy.

Operation is easy that you just set a rod electrode onto oil tank, and a switch is changed into ON. In addition, daily cleaning is easy since it is easily removed.

In order to use it safely.

To avoid the risk of electrical shock by the charging of the fryer and the body, fry saver is equipped with a full grounding mechanism. In addition, since the automatic stop function works when the ground has failure, safety is thorough.

Oil life can be extended by a fry saver! (Comparative example of non-use / use of fry saver)

	Nonuse of fry saver	Fry saver use
Oil tank capacity	18ℓ	18ℓ
Monthly whole oil exchange frequency	(26days÷2) 13times	(26days÷3.5) 7.4times
Monthly oil usage ①	234ℓ (18ℓ×13)	133ℓ (18ℓ×7.4)
Monthly lubricating oil amount ②	26ℓ	21ℓ
Total monthly oil usage ③ (①+②)	260ℓ	154ℓ
Monthly oil use number (tank) ④ (③÷18)	14.4can	8.5can
Oil Charge/18ℓ ⑤	¥4,000	¥4,000
Monthly oil cost ⑥ (④×⑤)	¥57,600/month	¥34,000/month
Annual oil use cost (⑥×12)	¥691,200	¥408,000

■Experimental data for 18 liters tank. The real working days per month is calculated as the 26th.

■ 1 tank type

FRS-07S

List Price : ¥240,000 (tax-excluded)

■ 2 tank type

FRS-07W

List Price : ¥330,000 (tax-excluded)

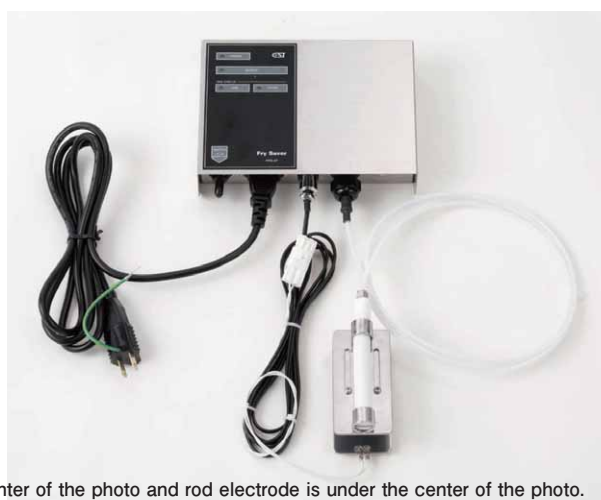

Controller is above the center of the photo and rod electrode is under the center of the photo.

■ fry saver compatible models

- MGF ————— all models (P2~P8)
- MXF ————— all models (P9~P12)
- MGF-CD ————— all models (P14~P15)
- MEF ————— all models (P16~P32)
- MEFD ————— all models (P35~P36)
- MIF ————— all models (P37~P43)

※Please contact us for other models.

■ Specifications Table

Model		FRS-07S (1 tank type)	FRS-07W (2 tank type)
Dimensions (mm)	Controller	200(W)×50(D)×168(H)	
	Rod electrode	15(φ)×135(H)	
Rod electrode number		1	2
Use power		1φ85~264V	50/60Hz
Power consumption		4.5W	5W

■Please contact us for delivery date.

Space-saving design of the easy-to-use size. Continuous and large-volume cooking can be realized.

This device has not installed equipment for getting rid of oil debris. In case of cooking to use bread crumbs, etc., a lot of oil debris will come out, so please clean the basket for receiving such oil debris frequently. Accumulation of oil debris is dangerous because it will be cause for overheating.

Easy cooking can be realized even for large volume of fried food.

A popular deep-fried food can be cooked just by putting ingredients onto this device. The ingredients automatically conveyed by the net will be carried to the exit chute with the delicious fried timing. You can cook large amounts of ingredients without labor. This cook is ideal for delicatessen shop, a restaurant, a supermarket, and delicatessen store.

Space-saving design that you do not have to choose the installation place.

Compact size in spite of a continuous automatic fryer. No need for choosing an installation place, making it easier to introduce in various stores in addition to a specialized store.

Rich flavor will be realized with the extreme infrared sheathed heater.

An extreme infrared sheathed heater avoids the local overheating of oil, which will reduce the degradation of the oil. So, a delicious food can be finished without missing the flavor of the food at any time. In addition, since the heater directly heats the oil in the oil tank, there is no economic waste in thermal efficiency. Reaching to the setting temperature is also speedy.

Accurate oil temperature, time and cooking management of the conveyor speed.

According to the menu, a microcomputer controls oil temperature, fried time and the conveyor speed. Oil temperature can be set from 60 °C to 220 °C by 1 °C. The oil temperature can be displayed in real time. Fried time can be adjusted from 2 minutes to 15 minutes.



The manual of the cooking can be carried out thanks to the 30 menus registration.

30 menus such as regular menu can be registered. A microcomputer controls oil temperature and fried time according to menu. Therefore, accurate cooking will be performed, contributing to manual of cooking and labor-saving.

Easy-to-clean swing-up method heater.

You can swing up the heater unit, making it easy to clean and replace the oil.

In addition, if the heater unit swings up while the electricity is applied, the power is turned OFF automatically.



Safety with overheating prevention mechanism and self-diagnosis function.

It is safety with overheating prevention mechanism including a built-in high limit switch to cut off the circuit automatically. If the oil temperature rises abnormally. In addition, it is also equipped with self-diagnosis function that error message is displayed in the case of any abnormality in the body.

Easy for oil drain work with oil drain cock.

Oil can be drained just by turning the cock. You can drain oil easily without removing the oil tank. Oil tanks can be smoothly moved with a caster.

■Cooking capacity table

Cooking name	Cooking temperature	Cooking time	Cooking capacity (pcs/h)		
			MEFR-09(T)	MEFR-12	MEFR-15
Croquette (frozen 60g)	180°C	4 minutes	420	600	770
Fried fish (frozen 60g)	175°C	4 minutes and 30 seconds	370	490	720
Bite-sized deep-fried breaded pork (chilled 40g)	160°C	3 minutes and 30 seconds	620	800	1,100
fried chicken (chilled 30g)	175°C	4 minutes	460	620	900

※Cooking ability slightly differs due to the input method of ingredients and the ingredient form.

Tabletop type

MEFR-09TR

List Price : ¥1,380,000 (tax-excluded)



Oil amount
28ℓ



Convenient dedicated stand is available (Please see the back cover)

- It can be also mounted on the cold table and so on thanks to the compact size, so you can utilize space effectively.

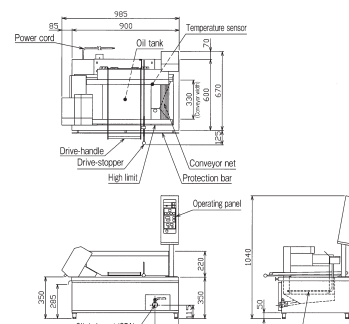

Electric continuous automatic fryer <small>

MEFR-09R

List Price : ¥1,400,000
(tax-excluded)



Oil amount
29 ℓ

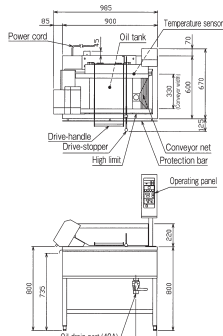

MEFR-12R

List Price : ¥1,520,000
(tax-excluded)



Oil amount
42 ℓ

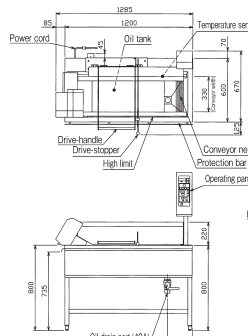

MEFR-15R

List Price : ¥1,740,000
(tax-excluded)



Oil amount
55 ℓ

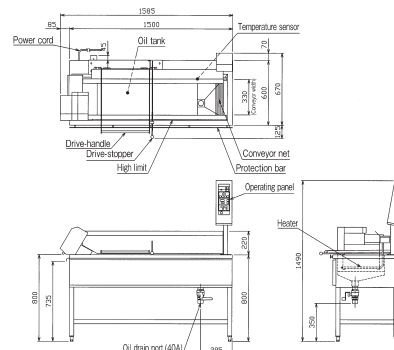

Electric continuous automatic fryer Specification Table

Model	External dimension (mm)			Conveyor width (mm)	Oil amount (ℓ)	Fried time (minutes)	Power (50/60Hz)	Power consumption (kW)	Necessary hand switch capacity	Power cord	Weight (kg)	Accessories						
	Width	Depth	Height									Oil tank	Oil screen	Sliding plate	Sliding plate for Tempura	Cover	Oil drain support	Adjust fixed plate
MEFR-09TR(L)(Tabletop)	985	670	350(1,040)	330	28	2~15	3 φ 200V	8.5	30A	2m 5.5mm ² -4 core direct connecting	81	S2	S2	1	1	1	1	4
MEFR-09R(L)	985	670	800(1,490)	330	29	2~15	3 φ 200V	8.5	30A	2m 5.5mm ² -4 core direct connecting	95	S2	S2	1	1	1		
MEFR-12R(L)	1,285	670	800(1,490)	330	42	2~15	3 φ 200V	10.9	40A	2m 8mm ² -4 core direct connecting	108	L2	L2	1	1	2		
MEFR-15R(L)	1,585	670	800(1,490)	330	55	2~15	3 φ 200V	13.9	50A	2m 14mm ² -4 core direct connecting	127	S1, L2	S1, L2	1	1	2		

■Dimensions in () include the operating unit. ■Model number end, R means that food inlet is right, while L shows that the food inlet is left.
■The delivery time of electric continuous automatic fryer is about 1 month after receipt of order.

Accessories

●There may have different sizes and specs depending on the model.

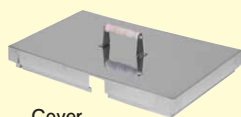

Cover



Oil tank



Oil screen

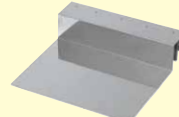

Sliding plate for Tempura



Sliding plate



Oil drain support (09T only)

Apron type that ingredients can be turned on from any part of the conveyor, and the ingredients having different cooking time can be fried at the same moment. **PATENTED**

Apron type of simple structure can cook efficiently.

The distance between the aprons is 133mm pitch, and effective range for fried cooking was divided into four. Further, since aprons for carrying foods move at a constant speed, the space is used without waste by changing the input location, and the foods can efficiently be fried at the time according to each characteristics of ingredients.

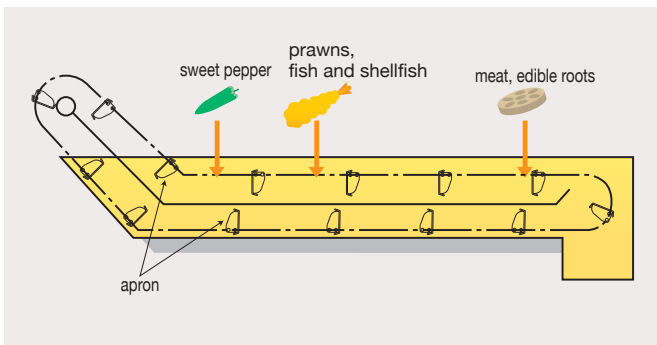
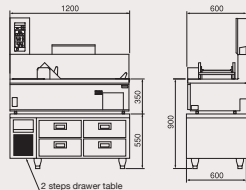

Table top type is easy to be combined with a working device because of compact size.

The height of the cooking surface is low, so when combined with other cooking equipment, you can make deep-fried food line in a small space.

Installation example in case putting on the drawer table



A variety of safety devices that can prevent trouble.

In addition to a torque limiter that does not damage the conveyor by the idling of gear automatically when food is caught in the conveyor, a conveyor emergency stop button is equipped. Safety device for making flame go out and a desuperheater will shut off the supply of gas in the case of emergency. It also provides self-diagnostic function that error message is displayed when an abnormality occurs in the body.

Accurate oil temperature, time and cooking management of the conveyor speed.

Microcomputer precisely controls the oil temperature, time, and the conveyor speed. Fried time can be set from 1 to 15 minutes, while oil temperature can be set from 100 to 220°C with 1°C unit. A variety of delicious fried conditions can meet your satisfaction.



30 menus can be memorized, resulting in cooking operation in manual.

Up to 30 menus such as regular menu and popular menu can be registered. Since the oil temperature and fried time can be automatically controlled, cooking in manual can be carried out, so contributing to labor savings.

Removable conveyor and apron.

Conveyor and apron can be removed from the body with simple operation. So, daily cleaning work can be easy.



Convenient Space for placing Hotel Pan.

There is a space for placing a hotel pan (2/3 size) to receive the fried ingredients. The work progresses efficiently.

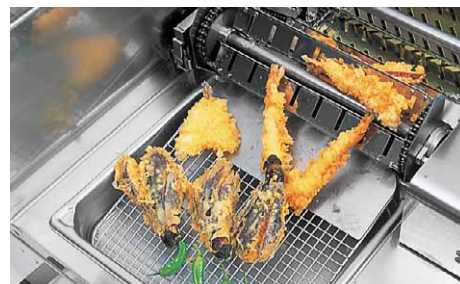

Easy oil drain work with an oil drain cock.

Drainage of oil can be worked just by turning an oil drain cock. Oil tanks can be smoothly moved with the caster.

Gas tabletop apron type conveyor fryer

MGFR-126TRB

List Price : ¥1,080,000
(tax-excluded)



Oil amount
20ℓ

Convenient dedicated stand is available
(Please see the back cover)

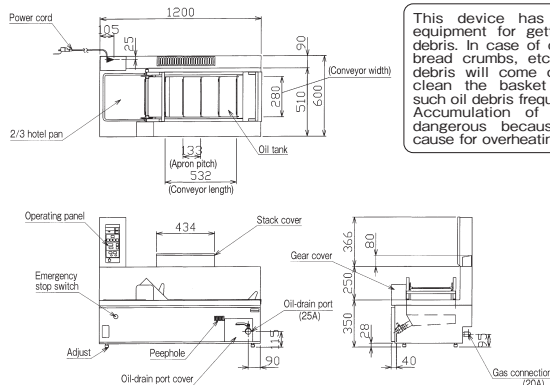

This device has not installed equipment for getting rid of oil debris. In case of cooking to use bread crumbs, etc., a lot of oil debris will come out, so please clean the basket for receiving such oil debris frequently. Accumulation of oil debris is dangerous because it will be cause for overheating.

Cooking capacity table [MGFR-126TR (L)B]

Cooking name	Cooking temperature	Cooking time	Cooking capacity (pcs/h)
Fried shrimp (frozen)	180°C	4 minutes	90
Chicken Nanban (frozen) (fried chicken with vinegar and tartar sauce)	180°C	5 minutes	48
Fried Squid (frozen)	180°C	6 minutes	40
The fried chicken (frozen)	180°C	6 minutes	80

※Cooking ability slightly differs due to the input method of ingredients and the ingredient form.

Gas tabletop apron type conveyor fryer Specifications Table.

Model	External dimension (mm)			Conveyor width (mm)	Oil amount (ℓ)	Time adjustment range	Gas consumption		Gas connection	Power consumption 1φ100V 50/60Hz (W)	Power cord	Accessories							Weight (kg)	
	Width	Depth	Height				Town gas	LP gas				Oil tank	Oil screen	2/3 Hotel pan	Oil drain pipe	Oil drain net	Oil debris receiver	Sliding plate		
MGFR-126TR(L)B	1,200	600	350	280	20	1~15	16.9kW (14,500kcal/h)	16.9kW (1,21kg/h)	20A	35	2.5m with plug (ground adapter)	L1	L1	1	1	1	1	1	1	100

■Model number end, R means that food ingredient inlet is right, while L is the inlet is left. ■The delivery time is about 1 month after receipt of order.

Accessories



For schools, hospitals, food service and central kitchen, it is most suitable for large volume cooking and on a large-scale kitchen.

Durable stainless oil tank is adopted!

Selectable 2 types and 4 models according to workability and kitchen layout.

Standard type

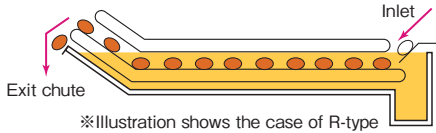

Ingredients input from Inlet will be conveyed between a conveying net and a net which goes under oil. Then ingredients will be automatically conveyed out from an exit chute without damaged, resulting in delicious uniformly-fried condition. Tempura can also be cooked by using an exclusive sliding plate.

U-turn type

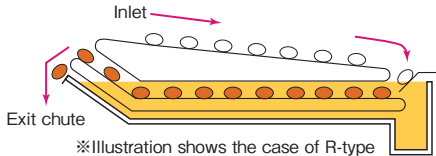

With this type input of ingredients is carried out on the side of exit chute and at the center of main body. Even one person can receive ingredients conveyed from the exit chute by setting the ingredients onto the conveyor.

Special combustion structure capable of continuously inputting frozen ingredients.

Maruzen original special combustion structure can realize speedy startup and excellent thermal efficiency by making effective use of exhaust heat. Frozen ingredients can also continuously be input, cooking a large volume of fried food in a short time. A burner is also placed at the exit chute side for long oil tank model (Model 20).

No-space-wasted design.

It is a compact design while keeping the necessary ability as continuous fryer for large volume cooking which is available even for a space-limited kitchen.

A device for automatically removing oil debris is equipped for all models.

So ingredients will not be attached with oil debris, which contributes to excellence in texture while suppressing oxidation of oil.



Accurate oil temperature, time and cooking management of the conveyor speed.

Microcomputer controls the oil temperature, fried time, and the conveyor speed according to menu. Oil temperature can be set from 60 to 220 °C with 1 °C unit, displaying oil temperature in real time. A fried time can be adjusted from 2 to 15 minutes.



30 menus can be memorized, resulting in cooking operation in manual.

30 menus such as a hot-selling menu can be registered in advance and can be operated with a single touch. The micro computer control can manually cook with accurate oil temperature and fried time, contributing to labor-saving.

A conveyor flip-up type which is easy for cleaning.

A conveyor net can easily be flipped up with special structural spring and the bottom part of oil tank is flat shape, so you can perform cleaning easily after cooking.



Comfortable working environment with concentrated exhaust system.

Special combustion structure includes a centralized exhaust system which gives comfortable working environment on kitchen by suppressing exhaust heat and by minimizing temperature rise.

Many safety features are provided.

Even if flame of a pilot burner disappears, a pilot safety device will operate and automatically shut off the supply of gas for preventing the outflow of raw gas. In addition, overheating prevention device will automatically shut off the gas when it detects an abnormal rise in the oil temperature. If an abnormal condition occurs in the body, the self-diagnostic function will display an error message.

Gas Continuous automatic fryer <Conveyor flyer> Specifications Table

Model	External dimension (mm)			Conveyor width (mm)	Oil amount (ℓ)	Fried time (minutes)	Gas consumption		Gas connection	Power consumption 1φ100V 50/60Hz (W)	Power cord	Capacity (60g frozen croquettes) (pcs/hour)	Accessories						Weight (kg)		
	Width	Depth	Height				City gas	LP gas					Oil tank	Oil screen	Sliding plate A	Sliding plate B	Input plate	Tempura plate		Special cover set	
MGFR-15R(L)C	1,595	1,375	1,310	547	62	2~15	41.9kW(36,000kcal/h)	41.9kW(3.00kg/h)	20A	67	2m with plug (ground adapter)	900	L3	L2, S1	1	1	1	1	1	323	
MGFR-20R(L)C	2,115	1,375	1,310	547	84	2~15	55.8kW(48,000kcal/h)	55.8kW(4.00kg/h)	20A	67		1,200	L4	L2, S2	1	1	1	1	1	403	
MGFR-15UR(L)C	1,765	1,375	1,310	547	62	2~15	41.9kW(36,000kcal/h)	41.9kW(3.00kg/h)	20A	67		900	L3	L2, S1						1	330
MGFR-20UR(L)C	2,270	1,375	1,310	547	84	2~15	55.8kW(48,000kcal/h)	55.8kW(4.00kg/h)	20A	67		1,200	L4	L2, S2						1	411

■Safety equipment: A pilot safety device, extreme overheating prevention device, and self failure diagnosis function with error display. ※These safety equipments have each slightly-different cooking ability according to input method and ingredient shape. ■In the Standard type R, ingredient input is on the right, while in the type L with ingredient input on the left. In the U-turn type R, ingredient input is on the left, while in the type L with ingredient input on the right. ■The delivery time of a gas continuous automatic fryer is about 1 month after receipt of order.

Standard type

MGFR-15RC

List Price : ¥1,850,000
(tax-excluded)



Oil amount
62ℓ

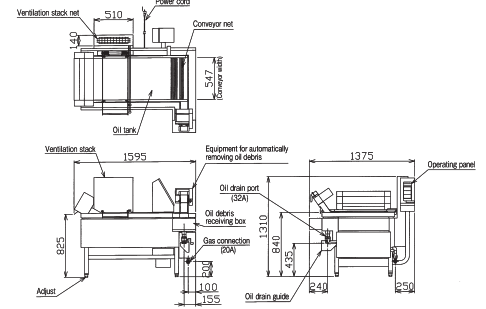

MGFR-20RC

List Price : ¥2,450,000
(tax-excluded)



Oil amount
84ℓ

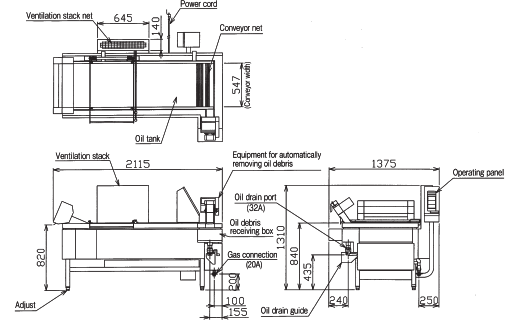

U-turn type

MGFR-15URC

List Price : ¥1,980,000
(tax-excluded)



Oil amount
62ℓ

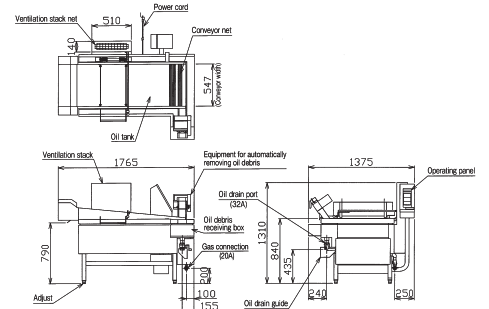

MGFR-20URC

List Price : ¥2,580,000
(tax-excluded)



Oil amount
84ℓ

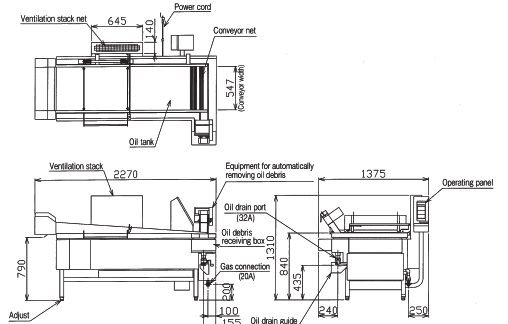

Option



Oil tank and oil filter (option) can be set under the table.

For Electric continuous automatic fryer (table type) and Tabletop apron type conveyer fryer, please use convenient special table.

■ Combination of MGFR-126TRB and special table : MGFR-12FT

■ Special table specifications table

Model	Adequate model	External dimension(mm)	List Price (tax-excluded)
MEFR-09FT	MEFR-09TR(L)	1,000×600×450	70,000
MGFR-12FT	MGFR-126TR(LB)	1,200×530×450	75,000

Products listed in this catalog offer types that conform to the specification of description of Minister of Land, Infrastructure and Transport Secretariat Government Buildings Department supervision "public building construction standard specifications" (machine equipment work), and please contact us for more information.

⚠ Safety Precautions

- Please receive "instruction manual" when purchasing equipments, and read carefully the "instruction manual" before using it. Please do not use for a purpose not described in "instruction manual" and for prohibited matter. Further, please do not use for purpose other than the intended use. Otherwise misuse will cause accidents such as carbon monoxide poisoning, fire and burn and will be cause of breakdown.
- Please do not use gaseous species and a power source (phase, voltage, frequency) not displayed in the main body. Otherwise, it will cause accident and will be cause of breakdown.
- Please do not disassemble or modify the equipment by all means. Otherwise, it will cause the accident or breakdown.

⚠ Precaution for Installation

- Equipment installing/moving work and ancillary facility works for such as gas, electricity, steam and water should be in accordance with Fire Service Act, Fire prevention ordinance and "Standards and Practical Guidelines for installing gas equipment". And please thoroughly read the manual instruction or working instruction and ask your dealer that you purchased or a specialized facility management company to properly install your product onto a safety place.
- In a place where a thermal equipment and an exhaust duct with an exhaust hood are installed, please use non-combustible materials such as concrete, brick and mortar for finishing and grounding (inside part of finishing) of equipment body's surrounding area and the upper surrounding area (backward, lateral, upper, floor face and ceiling)
- Where the finishing and grounding of the equipment body's surrounding area and the upper surrounding area are made by other material than non-combustible material when installing a thermal equipment and the exhaust duct with an exhaust hood, please install the equipment with offset distance specified for each equipment. Otherwise, it will cause a fire. Please carefully read "instruction manual" and "working instruction" for non-combustible material and installation standards.
- Be sure to install a heat-resistant/non-combustible exhaust duct with an exhaust hood upon the thermal equipment. As to equipments for generating oil smoke and steam, please install an exhaust duct with an exhaust hood which includes grease removing device. An exhaust fan of an exhaust duct should be operated while an air supply opening is absolutely necessary to be provided at an equipment-installed place.
- Please be sure so as not to extend an exhaust stack of the equipment using gas. Otherwise, it will lead to insufficient performance of equipment, accidents such as carbon monoxide poisoning, fire and burn, or breakdown.
- As to power source of equipment using electricity, please use a correctly-wired dedicated plug or a breaker separately. Be sure to install an earth for the prevention of electric shock (Third-class installation work)
- Please install not to be directly affected by the wind. Otherwise, it may cause insufficient performance or an accident such as fire by the flow of wind from an air conditioner.

⚠ CAUTION

- Please carry out adequate ventilation, i.e. by turning an exhaust fan when using the thermal equipment. It must be noted that insufficient ventilation will cause accident such as carbon monoxide poisoning due to incomplete combustion.
- Please do not leave the device when using because it is dangerous. Be sure to extinguish fire, close the gas main and turn off the power switch when you leave out from the equipment and do not use the equipment. Otherwise, it can cause a fire due to abnormal overheating.
- There is a possibility of causing fire if oil debris and dirt are accumulated too much at the equipment body's surrounding area, a gravy tray/waste oil receiver and a water tray. Please keep it clean.
- Please do not touch any part other than an operation unit because the equipment body and the surrounding part become hot during in use and soon after that. And please keep away your hand and face from the exhaust port. Or you may get burned.
- Do not apply water to equipment body and do not wash the whole part with water. Otherwise, it will cause the malfunction of equipment.
- If an emergency happens such as an earthquake, fire and gas leakage, please stop the usage of equipment and turn off the gas main.
- Please do not put any combustibles or flammables such as a spray, gasoline, benzene, etc upon the equipment and the surrounding area. It may cause fire.
- Please sufficiently consult with a specialized physician when a medical electronic device user such as a pacemaker will use an electromagnetic equipment.
- Products listed herein are for commercial purpose. For domestic use, be sure to consult with a dealer that you purchased or a specialized facility management company and properly install the equipment in accordance with prescribed installation standards.

- The visual appearance and specification of products listed on this catalog may partly be altered due to quality improvement without notice.
- The price in this catalogue may not be the latest one.

Costs for delivery, installation and withdrawal of old model are not included in this price.

General commercial kitchen Appliances & Equipment



MARUZEN Co., Ltd.

Listed on the second section of the Tokyo Stock Exchange (TSE)

<http://www.maruzen-kitchen.co.jp/>

■ Overseas Sales Office

2-19-18 Negishi, Taito-ku, Tokyo, Japan
Tel: 81-3-5603-5516 Fax: 81-3-5603-5517

■ Taiwan Maruzen Co., Ltd.

FL.12-3, No.202, Sec.2, Yen-ping North Rd., Taipei, Taiwan, R.O.C.
Tel: 886-2-2550-1355 Fax: 886-2-2550-1399

■ Maruzen (Thailand) Co., Ltd.

Room 184/193 Floor29-C3 Forum Tower Rachadaphisek Rd. Huai Khwang, Bangkok 10310 Thailand
TEL: 66-2-645-4242 FAX: 66-2-645-4241

■ contact

For professional use