

Noodle boiler <Backside exhaust-type>

Continuous cooking at high speed. Fastest boiling time in the market. Long-seller model with powerful boiling.

Backside exhaust type, safe working and more comfortable kitchen!

- With popular high power Chinese Range burner and Maruzen original bottom shape of pot, realized amazing boiling power. By efficient heating, boiled water comes out concentrated from the bottom of pot. Chewy and delicious noodle is cooked because boiling water is spouted in the tank.
- Safety by Backside exhaust type, which makes not to hit face or hands directly. In addition, adopted new design to decrease rear body temperature to greater extent than conventional.
- Adopted gas cock which can be changed from high to low heat by possible half-open gas cock. When not busy set to the half-open position, when busy set to the fully open position. It makes energy saving and improves usability.
- With high power burner and absorbing retained heat design, enabled continuous hot water pouring.
- Improved usability in the kitchen by making each corner at top plate R finishing.

MR-15M <Hayawaki> Continuous hot water spouting mechanism adopting new heat collector fin.

List Price : ¥434,000
(tax-excluded)

capacity
120 meals/h

New Hayawaki pot

Saving 40% fuel consumption
by adopted new heat collector fin
(compared to original)
Continuous hot water boiling mechanism

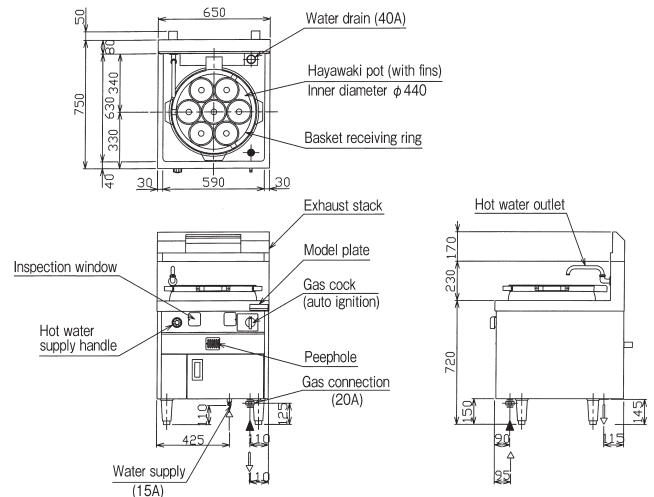



MR-31M

List Price : ¥408,000
(tax-excluded)

capacity
100 meals/h

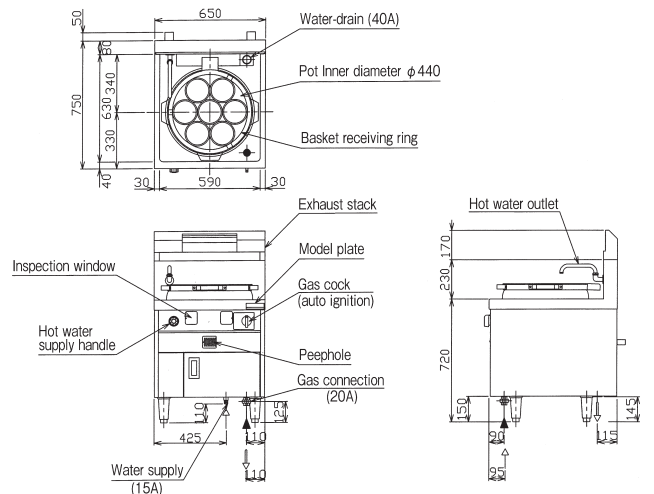
- Shape of pot bottom for 31M



■ Noodle boiler Specifications table

Model	External dimension (mm)				Pot quantity	Basket quantity	Pot water amount (ℓ)	Tank water amount (ℓ)	Gas consumption		Gas connection		Water supply	Water drain	Weight (kg)
	Width	Depth	Height	Back					Town gas	LP gas	Town gas	LP gas			
MR-15M	650	750	720	230	1	7	18.5	12	27.3kW (23,500kcal/h)	24.4kW (1.75kg/h)	20A	20A	15A	40A	95
MR-31M	650	750	720	230	1	7	18	12	27.3kW (23,500kcal/h)	24.4kW (1.75kg/h)	20A	20A	15A	40A	94

● Flame Rod is equipped. Auto ignition cock is adopted. ● Adopted hot water storage tank with safety valve.