



# PANORAMA

## BANCO pozzetti senza riserva / 1 level built-in pozzetti COUNTER



CARATTERISTICHE TECNICHE	OPTIONAL	TECHNICAL SPECIFICATIONS	OPTIONALS
<ul style="list-style-type: none"> <li>- vasca monoblocco schiumata in poliuretano iniettato a 40 kg/m<sup>3</sup></li> <li>- interno vasca in acciaio inox 18/10 AISI 304</li> <li>- piletta di scarico vasca con tappo di chiusura per facilitare le operazioni di sbrinamento e di pulizia</li> <li>- 1 livello di carapine</li> <li>- sistema anti-rotazione delle carapine</li> <li>- chiusura ermetica con ante in vetro piroclitico, temperato e riscaldato</li> <li>- illuminazione LED</li> <li>- refrigerazione ventilata</li> <li>- pannello comandi elettronico</li> <li>- sbrinamento manuale con arresto dell'impianto</li> </ul>	<ul style="list-style-type: none"> <li>- carapine con sistema anti-rotazione</li> <li>- lavaporizzatore</li> <li>- motore remoto</li> </ul>	<ul style="list-style-type: none"> <li>- monobloc foam tank insulated with injected polyurethane (40 kg/m<sup>3</sup>)</li> <li>- tank interior in 18/10 AISI 304 stainless steel</li> <li>- tank drains with plug to facilitate defrosting and cleaning operations</li> <li>- single level of 250 mm / 9.84" high gelato tubs</li> <li>- exclusive tubs anti-rotation system</li> <li>- tempered and heated airtight glass closure system</li> <li>- LED lighting</li> <li>- ventilated refrigeration system</li> <li>- electronic control panel</li> <li>- manual defrost function with system stoppage</li> </ul>	<ul style="list-style-type: none"> <li>- tubs with anti-rotation system</li> <li>- scoop washer</li> <li>- remote condensing unit</li> </ul>

### SEZIONE SECTION VIEW

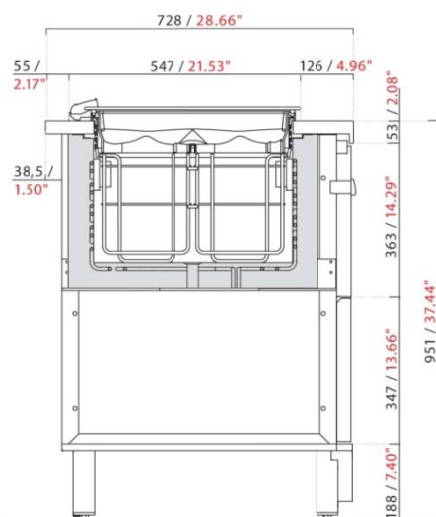

### BANCO PANORAMA SENZA RISERVA

PANORAMA pozzetti counter with 1 level of gelato tubs

### DIMENSIONI, PESO E IMBALLO DIMENSIONS, WEIGHT AND PACKAGING

MODELLO MODEL	LUNGHEZZA con 2 fianchi LENGTH with 2 end panels		PROFONDITÀ DEPTH		PESO WEIGHT		DIMENSIONE IMBALLO PACKAGING DIMENSIONS		PESO con imballo CRATED WEIGHT	
	mm	in	mm	in	kg	lb	mm	in	kg	lb
L 750	810	31.89"	728	28.66"	45	100	1124x911xH1367	44.3"x35.9"xH53.8"	82	181
L 1000	1060	41.73"	728	28.66"	60	132	1124x911xH1367	44.3"x35.9"xH53.8"	97	214
L 1250	1310	51.57"	728	28.66"	75	165	1624x911xH1367	63.9"x35.9"xH53.8"	126	278
L 1500	1560	61.42"	728	28.66"	90	198	1624x911xH1367	63.9"x35.9"xH53.8"	141	311
L 1750	1810	71.26"	728	28.66"	105	231	2124x911xH1367	83.6"x35.9"xH53.8"	169	373
L 2000	2060	81.10"	728	28.66"	120	265	2124x911xH1367	83.6"x35.9"xH53.8"	184	406
L 2250	2310	90.94"	728	28.66"	135	298	2624x911xH1367	103.3"x35.9"xH53.8"	213	470
L 2500	2560	100.79"	728	28.66"	150	331	2624x911xH1367	103.3"x35.9"xH53.8"	228	503
L 3000	3060	120.47"	728	28.66"	180	397	3124x911xH1367	123"x35.9"xH53.8"	272	600
L 3500	3560	140.16"	728	28.66"	210	463	3724x1074xH1367	146.6"x42.3"xH53.8"	336	741
L 4000	4060	159.84"	728	28.66"	240	529	4224x1074xH1367	166.3"x42.3"xH53.8"	382	842

**1 TEMPERATURA 1 TEMPERATURE**

**MODULI UC = con motore a bordo** UC units = with built-in air-cooled condensing unit

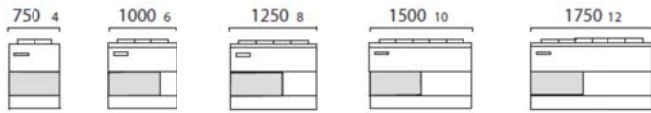

**MODULI NUC = con motore remoto** NUC units = with remote condensing unit

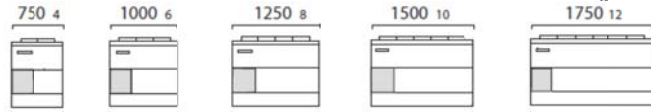

**2 TEMPERATURE 2 TEMPERATURES**

**MODULI UC = con motore a bordo** UC units = with built-in air-cooled condensing unit

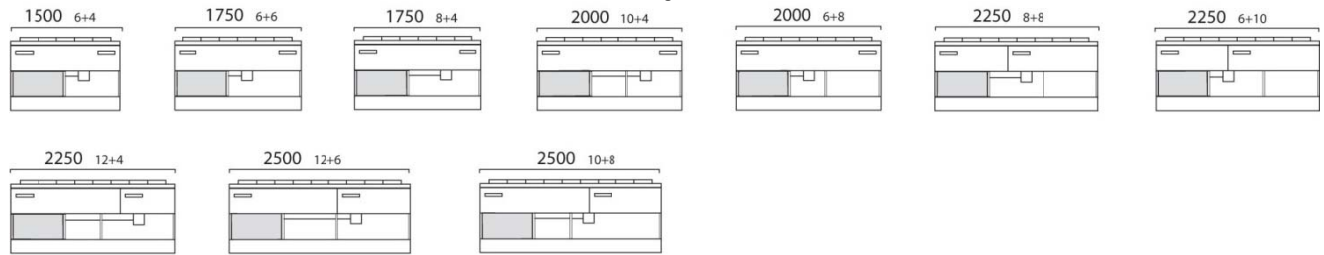

**MODULI NUC = con motore remoto** NUC units = with remote condensing unit

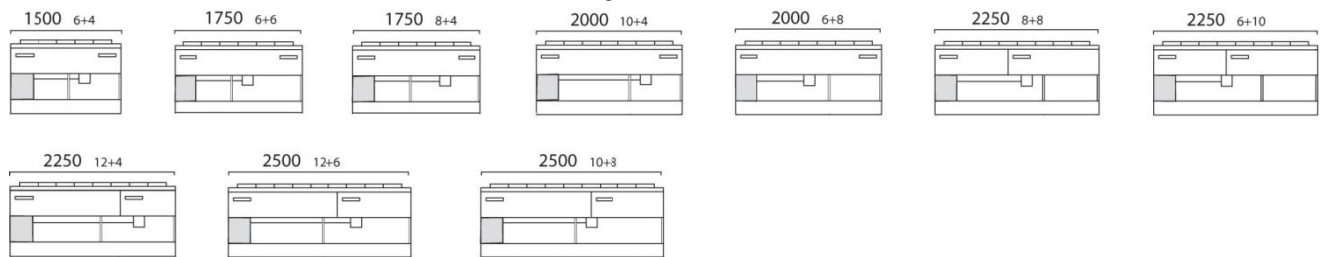

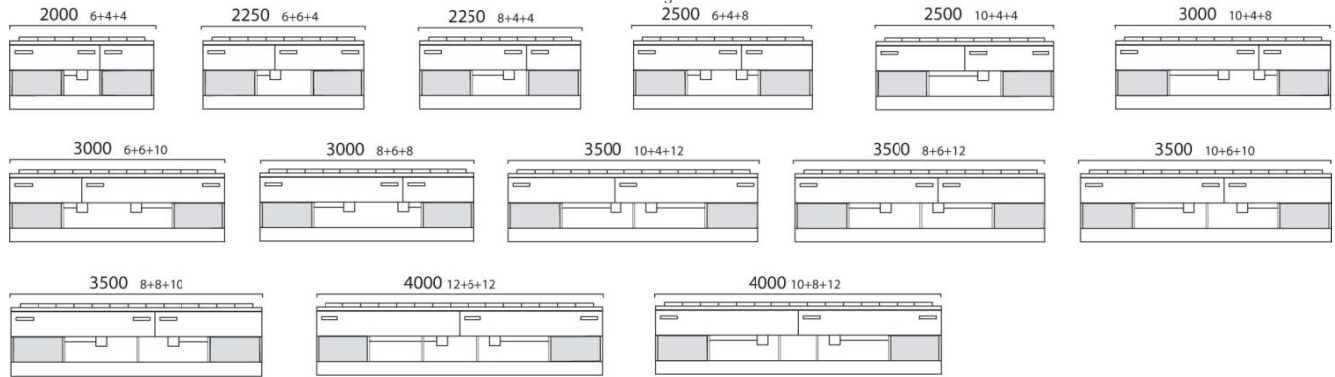

**3 TEMPERATURE 3 TEMPERATURES**

**MODULI UC = con motore a bordo** UC units = with built-in air-cooled condensing unit

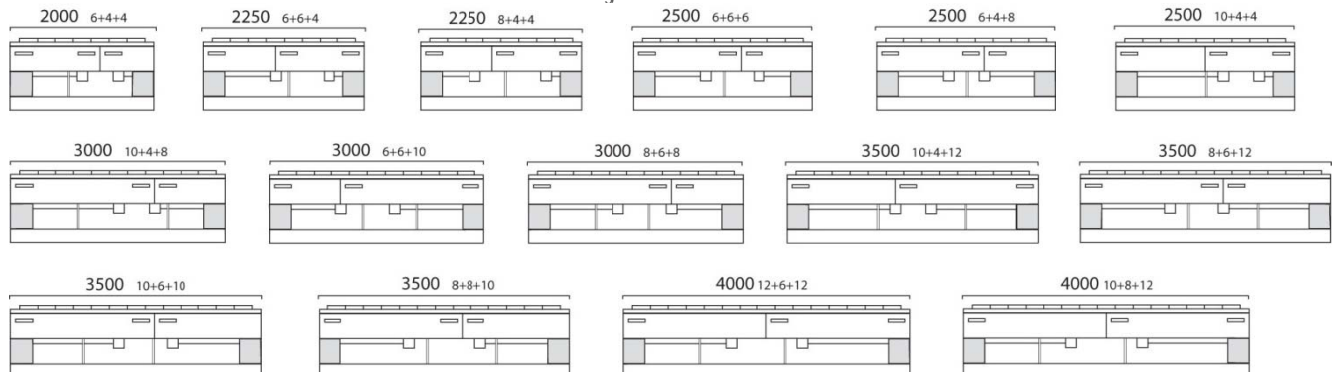

**MODULI NUC = con motore remoto** NUC units = with remote condensing unit





			UC = con motore a bordo UC = with built-in air-cooled condensing unit  NUC = con motore remoto entro 10 metri NUC = with condensing unit within 20 meters				TENSIONE E FREQUENZA VOLTAGE AND FREQUENCY  V/Ph/Hz <b>208-220/1/60</b>				
MODELLO MODEL	POTENZA COMP.HP	BREAKER SIZE	MCA	MOP	RESA CAPACITY	CLASSE CLIMATICA CLIMATE CLASS			TEMPERATURA DI ESERCIZIO OPERATING TEMPERATURE		
1 TEMPERATURA 1 TEMPERATURE	HP	A	A	A	W/h -30°C	BTU/h -22°F	°C	°F	U.R. R.H.	°C	°F
4 pozzetti	1/2	8	7	10	460	1.569	30°C	86°F	55%	-2°C; -18°C	+28.4°F; -0.4°F
6 pozzetti	1/2	8	7	10	460	1.569	30°C	86°F	55%	-2°C; -18°C	+28.4°F; -0.4°F
8 pozzetti	5/8	8	6	8	502	1.712	30°C	86°F	55%	-2°C; -18°C	+28.4°F; -0.4°F
10 pozzetti	5/8	8	6	9	502	1.712	30°C	86°F	55%	-2°C; -18°C	+28.4°F; -0.4°F
12 pozzetti	5/8	8	6	9	502	1.712	30°C	86°F	55%	-2°C; -18°C	+28.4°F; -0.4°F

			UC = con motore a bordo UC = with built-in air-cooled condensing unit  NUC = con motore remoto entro 10 metri NUC = with condensing unit within 20 meters				TENSIONE E FREQUENZA VOLTAGE AND FREQUENCY  V/Ph/Hz <b>208-220/1/60</b>				
MODELLO MODEL	POTENZA COMP.HP	BREAKER SIZE	MCA	MOP	RESA CAPACITY	CLASSE CLIMATICA CLIMATE CLASS			TEMPERATURA DI ESERCIZIO OPERATING TEMPERATURE		
2 TEMPERATURE 2 TEMPERATURES	HP	A	A	A	W/h -30°C	BTU/h -22°F	°C	°F	U.R. R.H.	°C	°F
L 1500 - 6+4	5/8	8	6	9	502	1.712	30°C	86°F	55%	-2°C; -18°C	+28.4°F; -0.4°F
L 1750 - 6+6	5/8	8	6	9	502	1.712	30°C	86°F	55%	-2°C; -18°C	+28.4°F; -0.4°F
L 1750 - 8+4	5/8	8	6	9	502	1.712	30°C	86°F	55%	-2°C; -18°C	+28.4°F; -0.4°F
L 2000 - 10+4	1,2	10	8	12	925	3.154	30°C	86°F	55%	-2°C; -18°C	+28.4°F; -0.4°F
L 2000 - 6+8	1,2	10	8	12	925	3.154	30°C	86°F	55%	-2°C; -18°C	+28.4°F; -0.4°F
L 2250 - 8+8	1,2	10	9	12	925	3.154	30°C	86°F	55%	-2°C; -18°C	+28.4°F; -0.4°F
L 2250 - 6+10	1,2	10	9	12	925	3.154	30°C	86°F	55%	-2°C; -18°C	+28.4°F; -0.4°F
L 2250 - 12+4	1,2	10	9	12	925	3.154	30°C	86°F	55%	-2°C; -18°C	+28.4°F; -0.4°F
L 2500 - 12+6	1,2	10	9	12	925	3.154	30°C	86°F	55%	-2°C; -18°C	+28.4°F; -0.4°F
L 2500 - 10+8	1,2	10	9	12	925	3.154	30°C	86°F	55%	-2°C; -18°C	+28.4°F; -0.4°F

			UC = con motore a bordo UC = with built-in air-cooled condensing unit  NUC = con motore remoto entro 10 metri NUC = with condensing unit within 20 meters				TENSIONE E FREQUENZA VOLTAGE AND FREQUENCY  V/Ph/Hz <b>208-220/1/60</b>				
MODELLO MODEL	POTENZA COMP.HP	BREAKER SIZE	MCA	MOP	RESA CAPACITY	CLASSE CLIMATICA CLIMATE CLASS			TEMPERATURA DI ESERCIZIO OPERATING TEMPERATURE		
3 TEMPERATURE 3 TEMPERATURES	HP	A	A	A	W/h -30°C	BTU/h -22°F	°C	°F	U.R. R.H.	°C	°F
* L 2000 6+4+4	5/8+1/2	8+8	6+7	9+10	502+460	1.712+1.569	30°C	86°F	55%	-2°C; -18°C	+28.4°F; -0.4°F
* L 2250 6+6+4	5/8+1/2	8+8	6+7	9+10	502+460	1.712+1.569	30°C	86°F	55%	-2°C; -18°C	+28.4°F; -0.4°F
* L 2250 8+4+4	5/8+1/2	8+8	6+7	9+10	502+460	1.712+1.569	30°C	86°F	55%	-2°C; -18°C	+28.4°F; -0.4°F
* L 2500 6+4+8	5/8+5/8	8+8	6+6	9+8	502+502	1.712+1.712	30°C	86°F	55%	-2°C; -18°C	+28.4°F; -0.4°F
* L 2500 10+4+4	1,2+1/2	10+8	8+7	12+10	925+460	3.154+1.569	30°C	86°F	55%	-2°C; -18°C	+28.4°F; -0.4°F
*L 3000 10+4+8	1,2+5/8	8+8	6+6	9+8	925+502	3.154+1.712	30°C	86°F	55%	-2°C; -18°C	+28.4°F; -0.4°F
*L 3000 6+6+10	5/8+5/8	8+8	6+6	9+9	502+502	1.712+1.712	30°C	86°F	55%	-2°C; -18°C	+28.4°F; -0.4°F
*L 3000 8+6+8	1,2+5/8	8+8	6+6	9+8	925+502	3.154+1.712	30°C	86°F	55%	-2°C; -18°C	+28.4°F; -0.4°F
*L 3500 10+4+12	1,2+5/8	8+8	6+6	9+9	925+502	3.154+1.712	30°C	86°F	55%	-2°C; -18°C	+28.4°F; -0.4°F
*L 3500 8+6+12	1,2+5/8	8+8	6+6	9+9	925+502	3.154+1.712	30°C	86°F	55%	-2°C; -18°C	+28.4°F; -0.4°F
*L 3500 10+6+10	1,2+5/8	8+8	6+6	9+9	925+502	3.154+1.712	30°C	86°F	55%	-2°C; -18°C	+28.4°F; -0.4°F
*L 3500 8+8+10	1,2+5/8	8+8	6+6	9+9	925+502	3.154+1.712	30°C	86°F	55%	-2°C; -18°C	+28.4°F; -0.4°F
*L 4000 12+6+12	1,2+5/8	8+8	6+6	9+9	925+502	3.154+1.712	30°C	86°F	55%	-2°C; -18°C	+28.4°F; -0.4°F
*L 4000 10+8+12	1,2+5/8	8+8	6+6	9+9	925+502	3.154+1.712	30°C	86°F	55%	-2°C; -18°C	+28.4°F; -0.4°F

\*2 compressori / 2 allacci elettrici \*2 condensing units / 2 electrical connections

	<b>UC</b> CON MOTORE A BORDO WITH BUILT-IN AIR-COOLED CONDENSING UNIT				<b>TENSIONE E FREQUENZA VOLTAGE AND FREQUENCY</b>				
					MONOFASE - V/Ph/Hz <b>230/1/50</b>				
MODELLO MODEL	POTENZA ASSORBITA CURRENT CONSUMPTION		RESA COOLING CAPACITY		CLASSE CLIMATICA CLIMATE CLASS			TEMPERATURA DI ESERCIZIO OPERATING TEMPERATURE	
<b>1 TEMPERATURA</b> <b>1 TEMPERATURE</b>	monofase 230/1/50		monofase 230/1/50		°C	°F	U.R. R.H.	°C	°F
	W	A	W/h -30°C	BTU/h -22°F					
L 750 UC - 4 pozzetti	504	3.25	460	1.570	30°C	86°F	55%	-2°C; -18°C	+28.4°F; -0.4°F
L 1000 UC - 6 pozzetti	545	3.43	460	1.570	30°C	86°F	55%	-2°C; -18°C	+28.4°F; -0.4°F
L 1250 UC - 8 pozzetti	746	3.95	615	2.100	30°C	86°F	55%	-2°C; -18°C	+28.4°F; -0.4°F
L 1500 UC - 10 pozzetti	792	4.15	615	2.100	30°C	86°F	55%	-2°C; -18°C	+28.4°F; -0.4°F
L 1750 UC - 12 pozzetti	838	4.35	615	2.100	30°C	86°F	55%	-2°C; -18°C	+28.4°F; -0.4°F

	<b>UC</b> CON MOTORE A BORDO WITH BUILT-IN AIR-COOLED CONDENSING UNIT				<b>TENSIONE E FREQUENZA VOLTAGE AND FREQUENCY</b>				
					MONOFASE - V/Ph/Hz <b>230/1/50</b>				
MODELLO MODEL	POTENZA ASSORBITA CURRENT CONSUMPTION		RESA COOLING CAPACITY		CLASSE CLIMATICA CLIMATE CLASS			TEMPERATURA DI ESERCIZIO OPERATING TEMPERATURE	
<b>2 TEMPERATURE</b> <b>2 TEMPERATURES</b>	monofase 230/1/50		monofase 230/1/50		°C	°F	U.R. R.H.	°C	°F
	W	A	W/h -30°C	BTU/h -22°F					
L 1500 UC - 6+4 pozzetti	792	4.15	615	2.100	30°C	86°F	55%	-2°C; -18°C	+28.4°F; -0.4°F
L 1750 UC - 6+6 pozzetti	838	4.35	615	2.100	30°C	86°F	55%	-2°C; -18°C	+28.4°F; -0.4°F
L 1750 UC - 8+4 pozzetti	838	4.35	615	2.100	30°C	86°F	55%	-2°C; -18°C	+28.4°F; -0.4°F
L 2000 UC - 10+4 pozzetti	1037	5.02	925	3.154	30°C	86°F	55%	-2°C; -18°C	+28.4°F; -0.4°F
L 2000 UC - 6+8 pozzetti	1037	5.02	925	3.154	30°C	86°F	55%	-2°C; -18°C	+28.4°F; -0.4°F
L 2250 UC - 8+8 pozzetti	1078	5.20	925	3.154	30°C	86°F	55%	-2°C; -18°C	+28.4°F; -0.4°F
L 2250 UC - 6+10 pozzetti	1078	5.20	925	3.154	30°C	86°F	55%	-2°C; -18°C	+28.4°F; -0.4°F
L 2250 UC - 12+4 pozzetti	1078	5.20	925	3.154	30°C	86°F	55%	-2°C; -18°C	+28.4°F; -0.4°F
L 2500 UC - 12+6 pozzetti	1118	5.38	925	3.154	30°C	86°F	55%	-2°C; -18°C	+28.4°F; -0.4°F
L 2500 UC - 10+8 pozzetti	1118	5.38	925	3.154	30°C	86°F	55%	-2°C; -18°C	+28.4°F; -0.4°F

	<b>UC</b> CON MOTORE A BORDO WITH BUILT-IN AIR-COOLED CONDENSING UNIT				<b>TENSIONE E FREQUENZA VOLTAGE AND FREQUENCY</b>				
					MONOFASE - V/Ph/Hz <b>230/1/50</b>				
MODELLO MODEL	POTENZA ASSORBITA CURRENT CONSUMPTION		RESA COOLING CAPACITY		CLASSE CLIMATICA CLIMATE CLASS			TEMPERATURA DI ESERCIZIO OPERATING TEMPERATURE	
<b>3 TEMPERATURE</b> <b>3 TEMPERATURES</b>	monofase 230/1/50		monofase 230/1/50		°C	°F	U.R. R.H.	°C	°F
	W	A	W/h -30°C	BTU/h -22°F					
* L 2000 UC - 6+4+4	1296	7.40	615+460	2.100+1.569	30°C	86°F	55%	-2°C; -18°C	+28.4°F; -0.4°F
* L 2250 UC - 6+6+4	1342	7.60	615+460	2.100+1.569	30°C	86°F	55%	-2°C; -18°C	+28.4°F; -0.4°F
* L 2250 UC - 8+4+4	1342	7.60	615+460	2.100+1.569	30°C	86°F	55%	-2°C; -18°C	+28.4°F; -0.4°F
* L 2500 UC - 6+4+8	1538	8.10	615+615	2.100+2.100	30°C	86°F	55%	-2°C; -18°C	+28.4°F; -0.4°F
* L 2500 UC - 10+4+4	1541	8.27	925+460	3.154+1.569	30°C	86°F	55%	-2°C; -18°C	+28.4°F; -0.4°F
* L 3000 UC - 10+4+8	1783	8.97	615+925	2.100+3.154	30°C	86°F	55%	-2°C; -18°C	+28.4°F; -0.4°F
* L 3000 UC - 6+6+10	1630	8.50	615+615	2.100+2.100	30°C	86°F	55%	-2°C; -18°C	+28.4°F; -0.4°F
* L 3000 UC - 8+6+8	1783	8.97	925+615	3.154+2.100	30°C	86°F	55%	-2°C; -18°C	+28.4°F; -0.4°F
* L 3500 UC - 10+4+12	1875	9.37	925+615	3.154+2.100	30°C	86°F	55%	-2°C; -18°C	+28.4°F; -0.4°F
* L 3500 UC - 8+6+12	1875	9.37	925+615	3.154+2.100	30°C	86°F	55%	-2°C; -18°C	+28.4°F; -0.4°F
* L 3500 UC - 10+6+10	1870	9.35	925+615	3.154+2.100	30°C	86°F	55%	-2°C; -18°C	+28.4°F; -0.4°F
* L 3500 UC - 8+8+10	1870	9.35	925+615	3.154+2.100	30°C	86°F	55%	-2°C; -18°C	+28.4°F; -0.4°F
* L 4000 UC - 12+6+12	1956	9.73	925+615	3.154+2.100	30°C	86°F	55%	-2°C; -18°C	+28.4°F; -0.4°F
* L 4000 UC - 10+8+12	1956	9.73	925+615	3.154+2.100	30°C	86°F	55%	-2°C; -18°C	+28.4°F; -0.4°F

\*2 compressori / 2 allacci elettrici \*2 condensing units / 2 electrical connections

MODELLO MODEL	POTENZA ASSORBITA CURRENT CONSUMPTION				RESA COOLING CAPACITY		CLASSE CLIMATICA CLIMATE CLASS			TEMPERATURA DI ESERCIZIO OPERATING TEMPERATURE	
	monofase 230/1/50		A		monofase 230/1/50		°C	°F	U.R. R.H.	°C	°F
L 750 NUC - 4 pozzetti	629	3.35	615	2.100	30°C	86°F	55%	-2°C; -18°C	+28.4°F; -0.4°F		
L 1000 NUC - 6 pozzetti	670	3.53	615	2.100	30°C	86°F	55%	-2°C; -18°C	+28.4°F; -0.4°F		
L 1250 NUC - 8 pozzetti	720	3.75	615	2.100	30°C	86°F	55%	-2°C; -18°C	+28.4°F; -0.4°F		
L 1500 NUC - 10 pozzetti	862	3.20	925	3.154	30°C	86°F	55%	-2°C; -18°C	+28.4°F; -0.4°F		
L 1750 NUC - 12 pozzetti	908	3.40	925	3.154	30°C	86°F	55%	-2°C; -18°C	+28.4°F; -0.4°F		

MODELLO MODEL	POTENZA ASSORBITA CURRENT CONSUMPTION				RESA COOLING CAPACITY		CLASSE CLIMATICA CLIMATE CLASS			TEMPERATURA DI ESERCIZIO OPERATING TEMPERATURE	
	monofase 230/1/50		A		monofase 230/1/50		°C	°F	U.R. R.H.	°C	°F
L 1500 NUC - 6+4 pozzetti	862	3.20	925	3.154	30°C	86°F	55%	-2°C; -18°C	+28.4°F; -0.4°F		
L 1750 NUC - 6+6 pozzetti	908	3.40	925	3.154	30°C	86°F	55%	-2°C; -18°C	+28.4°F; -0.4°F		
L 1750 NUC - 8+4 pozzetti	908	3.40	925	3.154	30°C	86°F	55%	-2°C; -18°C	+28.4°F; -0.4°F		
L 2000 NUC - 10+4 pozzetti	947	3.57	925	3.154	30°C	86°F	55%	-2°C; -18°C	+28.4°F; -0.4°F		
L 2000 NUC - 6+8 pozzetti	947	3.57	925	3.154	30°C	86°F	55%	-2°C; -18°C	+28.4°F; -0.4°F		
L 2250 NUC - 8+8 pozzetti	988	3.75	925	3.154	30°C	86°F	55%	-2°C; -18°C	+28.4°F; -0.4°F		
L 2250 NUC - 6+10 pozzetti	988	3.75	925	3.154	30°C	86°F	55%	-2°C; -18°C	+28.4°F; -0.4°F		
L 2250 NUC - 12+4 pozzetti	988	3.75	925	3.154	30°C	86°F	55%	-2°C; -18°C	+28.4°F; -0.4°F		
L 2500 NUC - 12+6 pozzetti	1028	3.93	925	3.154	30°C	86°F	55%	-2°C; -18°C	+28.4°F; -0.4°F		
L 2500 NUC - 10+8 pozzetti	1028	3.93	925	3.154	30°C	86°F	55%	-2°C; -18°C	+28.4°F; -0.4°F		

MODELLO MODEL	POTENZA ASSORBITA CURRENT CONSUMPTION				RESA COOLING CAPACITY		CLASSE CLIMATICA CLIMATE CLASS			TEMPERATURA DI ESERCIZIO OPERATING TEMPERATURE	
	monofase 230/1/50		A		monofase 230/1/50		°C	°F	U.R. R.H.	°C	°F
* L 2000 NUC - 6+4+4	1491	7.45	925+615	3.154+2.100	30°C	86°F	55%	-2°C; -18°C	+28.4°F; -0.4°F		
* L 2250 NUC - 6+6+4	1537	7.65	925+615	3.154+2.100	30°C	86°F	55%	-2°C; -18°C	+28.4°F; -0.4°F		
* L 2250 NUC - 8+4+4	1537	7.65	925+615	3.154+2.100	30°C	86°F	55%	-2°C; -18°C	+28.4°F; -0.4°F		
* L 2500 NUC - 6+4+8	1582	7.85	925+615	3.154+2.100	30°C	86°F	55%	-2°C; -18°C	+28.4°F; -0.4°F		
* L 2500 NUC - 6+6+6	1578	7.83	925+615	3.154+2.100	30°C	86°F	55%	-2°C; -18°C	+28.4°F; -0.4°F		
* L 2500 NUC - 10+4+4	1576	7.82	925+615	3.154+2.100	30°C	86°F	55%	-2°C; -18°C	+28.4°F; -0.4°F		
* L 3000 NUC - 10+4+8	1667	7.32	925+615	3.154+2.100	30°C	86°F	55%	-2°C; -18°C	+28.4°F; -0.4°F		
* L 3000 NUC - 6+6+10	1770	6.60	925+925	3.154+3.154	30°C	86°F	55%	-2°C; -18°C	+28.4°F; -0.4°F		
* L 3000 NUC - 8+6+8	1667	7.32	925+615	3.154+2.100	30°C	86°F	55%	-2°C; -18°C	+28.4°F; -0.4°F		
* L 3500 NUC - 10+4+12	1855	6.97	925+925	3.154+3.154	30°C	86°F	55%	-2°C; -18°C	+28.4°F; -0.4°F		
* L 3500 NUC - 8+6+12	1855	6.97	925+925	3.154+3.154	30°C	86°F	55%	-2°C; -18°C	+28.4°F; -0.4°F		
* L 3500 NUC - 10+6+10	1850	6.95	925+925	3.154+3.154	30°C	86°F	55%	-2°C; -18°C	+28.4°F; -0.4°F		
* L 3500 NUC - 8+8+10	1850	6.95	925+925	3.154+3.154	30°C	86°F	55%	-2°C; -18°C	+28.4°F; -0.4°F		
* L 4000 NUC - 12+6+12	1936	7.33	925+925	3.154+3.154	30°C	86°F	55%	-2°C; -18°C	+28.4°F; -0.4°F		
* L 4000 NUC - 10+8+12	1936	7.33	925+925	3.154+3.154	30°C	86°F	55%	-2°C; -18°C	+28.4°F; -0.4°F		

\*2 compressori / 2 allacci elettrici \*2 condensing units / 2 electrical connections



# PANORAMA

## BANCO pozzetti con riserva / 2 level built-in pozzetti COUNTER



CARATTERISTICHE TECNICHE	TECHNICAL SPECIFICATIONS	OPTIONAL	OPTIONALS
<ul style="list-style-type: none"> <li>- vasca monoblocco schiumata in poliuretano iniettato a 40 kg/m<sup>3</sup></li> <li>- interno vasca in acciaio inox 18/10 AISI 304</li> <li>- piletta di scarico vasca con tappo di chiusura per facilitare le operazioni di sbrinamento e di pulizia</li> <li>- 2 livelli di carapine H 250 mm</li> <li>- sistema anti-rotazione delle carapine</li> <li>- chiusura ermetica con ante in vetro piroclitico, temperato e riscaldato</li> <li>- illuminazione LED</li> <li>- refrigerazione ventilata</li> <li>- pannello comandi elettronico</li> <li>- sbrinamento manuale con arresto dell'impianto</li> </ul>	<ul style="list-style-type: none"> <li>- carapine con sistema anti-rotazione</li> <li>- lavaporizzatore</li> <li>- motore remoto</li> </ul>	<ul style="list-style-type: none"> <li>- monobloc foam tank insulated with injected polyurethane (40 kg/m<sup>3</sup>)</li> <li>- tank interior in 18/10 AISI 304 stainless steel</li> <li>- tank drains with plug to facilitate defrosting and cleaning operations</li> <li>- double level of 250 mm / 9.84" high gelato tubs</li> <li>- exclusive tubs anti-rotation system</li> <li>- tempered and heated airtight glass closure system</li> <li>- LED lighting</li> <li>- ventilated refrigeration system</li> <li>- electronic control panel</li> <li>- manual defrost function with system stoppage</li> </ul>	<ul style="list-style-type: none"> <li>- tubs with anti-rotation system</li> <li>- scoop washer</li> <li>- remote condensing unit</li> </ul>

### SEZIONE SECTION VIEW

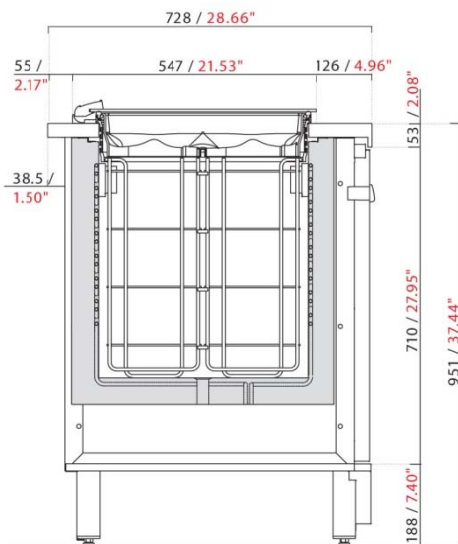

### BANCO PANORAMA CON RISERVA

PANORAMA pozzetti counter with 2 levels of gelato tubs

### DIMENSIONI, PESO E IMBALLO DIMENSIONS, WEIGHT AND PACKAGING

MODELLO MODEL	LUNGHEZZA con 2 fianchi LENGTH with 2 end panels		PROFONDITÀ DEPTH		PESO WEIGHT		DIMENSIONE IMBALLO PACKAGING DIMENSIONS		PESO con imballo CRATED WEIGHT	
	mm	in	mm	in	kg	lb	mm	in	kg	lb
L 750	810	31.89"	728	28.66"	45	100	1124x911xH1367	44.3"x35.9"xH53.8"	82	181
L 1000	1060	41.73"	728	28.66"	60	132	1124x911xH1367	44.3"x35.9"xH53.8"	97	214
L 1250	1310	51.57"	728	28.66"	75	165	1624x911xH1367	63.9"x35.9"xH53.8"	126	278
L 1500	1560	61.42"	728	28.66"	90	198	1624x911xH1367	63.9"x35.9"xH53.8"	141	311
L 1750	1810	71.26"	728	28.66"	105	231	2124x911xH1367	83.6"x35.9"xH53.8"	169	373
L 2000	2060	81.10"	728	28.66"	120	265	2124x911xH1367	83.6"x35.9"xH53.8"	184	406
L 2250	2310	90.94"	728	28.66"	135	298	2624x911xH1367	103.3"x35.9"xH53.8"	213	470
L 2500	2560	100.79"	728	28.66"	150	331	2624x911xH1367	103.3"x35.9"xH53.8"	228	503
L 3000	3060	120.47"	728	28.66"	180	397	3124x911xH1367	123"x35.9"xH53.8"	272	600
L 3500	3560	140.16"	728	28.66"	210	463	3724x1074xH1367	146.6"x42.3"xH53.8"	336	741
L 4000	4060	159.84"	728	28.66"	240	529	4224x1074xH1367	166.3"x42.3"xH53.8"	382	842

## 1 TEMPERATURA 1 TEMPERATURE

MODULI UC = con motore a bordo UC units = with built-in air-cooled condensing unit

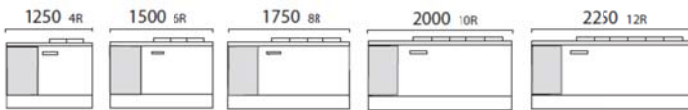

MODULI NUC = con motore remoto NUC units = with remote condensing unit

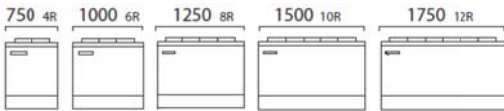

## 2 TEMPERATURE 2 TEMPERATURES

MODULI UC = con motore a bordo UC units = with built-in air-cooled condensing unit

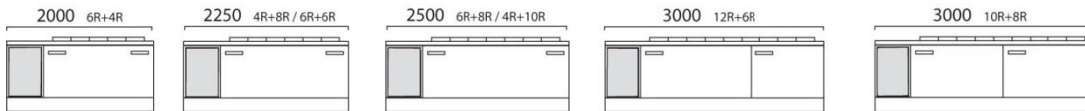

MODULI NUC = con motore remoto NUC units = with remote condensing unit

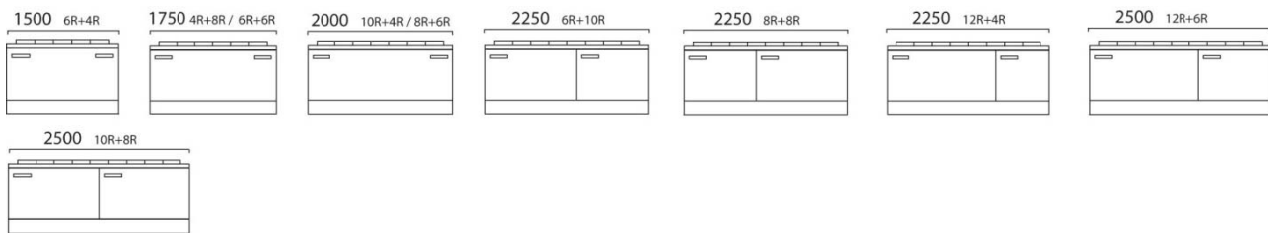

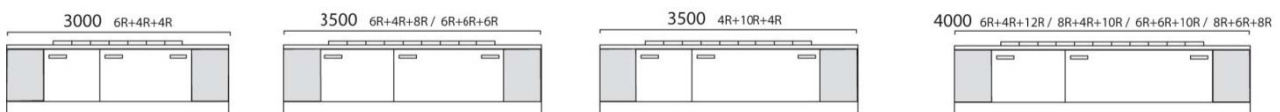

## 3 TEMPERATURE 3 TEMPERATURES

MODULI UC = con motore a bordo UC units = with built-in air-cooled condensing unit

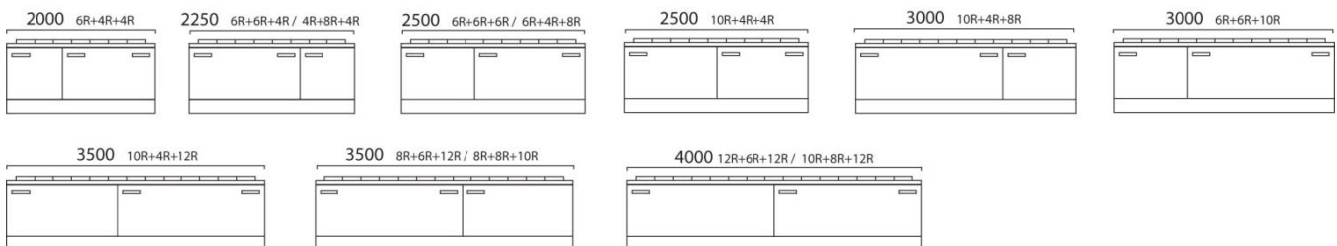

MODULI NUC = con motore remoto NUC units = with remote condensing unit



		UC = con motore a bordo UC = with built-in air-cooled condensing unit  NUC = con motore remoto entro 10 metri NUC = with condensing unit within 20 meters				TENSIONE E FREQUENZA VOLTAGE AND FREQUENCY  V/Ph/Hz <b>208-220/1/60</b>				
MODELLO MODEL	POTENZA COMP. HP	BREAKER SIZE	MCA	MOP	RESA CAPACITY	CLASSE CLIMATICA CLIMATE CLASS			TEMPERATURA DI ESERCIZIO OPERATING TEMPERATURE	
<b>1 TEMPERATURA 1 TEMPERATURE</b>	HP	<b>A</b>	<b>A</b>	<b>A</b>	W/h -30°C <b>BTU/h</b> -22°F	°C	°F	U.R. R.H.	°C	°F
4 pozzetti	1/2	8	7	10	460 1.569	30°C	86°F	55%	-2°C; -18°C	+28.4°F; -0.4°F
6 pozzetti	1/2	8	7	10	460 1.569	30°C	86°F	55%	-2°C; -18°C	+28.4°F; -0.4°F
8 pozzetti	5/8	8	6	8	502 1.712	30°C	86°F	55%	-2°C; -18°C	+28.4°F; -0.4°F
10 pozzetti	5/8	8	6	9	502 1.712	30°C	86°F	55%	-2°C; -18°C	+28.4°F; -0.4°F
12 pozzetti	5/8	8	6	9	502 1.712	30°C	86°F	55%	-2°C; -18°C	+28.4°F; -0.4°F

		UC = con motore a bordo UC = with built-in air-cooled condensing unit  NUC = con motore remoto entro 10 metri NUC = with condensing unit within 20 meters				TENSIONE E FREQUENZA VOLTAGE AND FREQUENCY  V/Ph/Hz <b>208-220/1/60</b>				
MODELLO MODEL	POTENZA COMP. HP	BREAKER SIZE	MCA	MOP	RESA CAPACITY	CLASSE CLIMATICA CLIMATE CLASS			TEMPERATURA DI ESERCIZIO OPERATING TEMPERATURE	
<b>2 TEMPERATURE 2 TEMPERATURES</b>	HP	<b>A</b>	<b>A</b>	<b>A</b>	W/h -30°C <b>BTU/h</b> -22°F	°C	°F	U.R. R.H.	°C	°F
6+4 pozzetti	5/8	8	6	9	502 1.712	30°C	86°F	55%	-2°C; -18°C	+28.4°F; -0.4°F
6+6 pozzetti	5/8	8	6	9	502 1.712	30°C	86°F	55%	-2°C; -18°C	+28.4°F; -0.4°F
4+8 pozzetti	5/8	8	6	9	502 1.712	30°C	86°F	55%	-2°C; -18°C	+28.4°F; -0.4°F
4+10 pozzetti	1,2	10	8	12	925 3.154	30°C	86°F	55%	-2°C; -18°C	+28.4°F; -0.4°F
6+8 pozzetti	1,2	10	8	12	925 3.154	30°C	86°F	55%	-2°C; -18°C	+28.4°F; -0.4°F
6+10 pozzetti	1,2	10	9	12	925 3.154	30°C	86°F	55%	-2°C; -18°C	+28.4°F; -0.4°F
8+8 pozzetti	1,2	10	9	12	925 3.154	30°C	86°F	55%	-2°C; -18°C	+28.4°F; -0.4°F
10+4 pozzetti	1,2	10	8	12	925 3.154	30°C	86°F	55%	-2°C; -18°C	+28.4°F; -0.4°F
10+8 pozzetti	1,2	10	9	12	925 3.154	30°C	86°F	55%	-2°C; -18°C	+28.4°F; -0.4°F
12+4 pozzetti	1,2	10	9	12	925 3.154	30°C	86°F	55%	-2°C; -18°C	+28.4°F; -0.4°F
12+6 pozzetti	1,2	10	9	12	925 3.154	30°C	86°F	55%	-2°C; -18°C	+28.4°F; -0.4°F

		UC = con motore a bordo UC = with built-in air-cooled condensing unit  NUC = con motore remoto entro 10 metri NUC = with condensing unit within 20 meters				TENSIONE E FREQUENZA VOLTAGE AND FREQUENCY  V/Ph/Hz <b>208-220/1/60</b>				
MODELLO MODEL	POTENZA COMP. HP	BREAKER SIZE	MCA	MOP	RESA CAPACITY	CLASSE CLIMATICA CLIMATE CLASS			TEMPERATURA DI ESERCIZIO OPERATING TEMPERATURE	
<b>3 TEMPERATURE 3 TEMPERATURES</b>	HP	<b>A</b>	<b>A</b>	<b>A</b>	W/h -30°C <b>BTU/h</b> -22°F	°C	°F	U.R. R.H.	°C	°F
*6+4+4 pozzetti	5/8+1/2	8+8	6+7	9+10	502+460 1.712+1.569	30°C	86°F	55%	-2°C; -18°C	+28.4°F; -0.4°F
*4+8+4 pozzetti	5/8+1/2	8+8	6+7	9+10	502+460 1.712+1.569	30°C	86°F	55%	-2°C; -18°C	+28.4°F; -0.4°F
*6+6+4 pozzetti	5/8+1/2	8+8	6+7	9+10	502+460 1.712+1.569	30°C	86°F	55%	-2°C; -18°C	+28.4°F; -0.4°F
*6+6+6 pozzetti	5/8+1/2	8+8	6+7	9+10	502+460 1.712+1.569	30°C	86°F	55%	-2°C; -18°C	+28.4°F; -0.4°F
*6+4+8 pozzetti	5/8+5/8	8+8	6+6	9+8	502+502 1.712+1.712	30°C	86°F	55%	-2°C; -18°C	+28.4°F; -0.4°F
*4+10+4 pozzetti	1,2+1/2	10+8	8+7	12+10	925+460 3.154+1.569	30°C	86°F	55%	-2°C; -18°C	+28.4°F; -0.4°F
*10+4+4 pozzetti	1,2+1/2	10+8	8+7	12+10	925+460 3.154+1.569	30°C	86°F	55%	-2°C; -18°C	+28.4°F; -0.4°F
*10+4+8 pozzetti	1,2+5/8	10+8	8+6	12+8	925+502 3.154+1.712	30°C	86°F	55%	-2°C; -18°C	+28.4°F; -0.4°F
*6+4+12 pozzetti	5/8+5/8	8+8	6+6	9+9	502+502 1.712+1.712	30°C	86°F	55%	-2°C; -18°C	+28.4°F; -0.4°F
*6+6+10 pozzetti	5/8+5/8	8+8	6+6	9+9	502+502 1.712+1.712	30°C	86°F	55%	-2°C; -18°C	+28.4°F; -0.4°F
*8+4+10 pozzetti	1,2+5/8	8+8	6+6	9+8	502+502 1.712+1.712	30°C	86°F	55%	-2°C; -18°C	+28.4°F; -0.4°F
*8+6+8 pozzetti	1,2+5/8	10+8	8+6	12+8	925+502 3.154+1.712	30°C	86°F	55%	-2°C; -18°C	+28.4°F; -0.4°F
*10+4+12 pozzetti	1,2+5/8	10+8	8+6	12+9	925+502 3.154+1.712	30°C	86°F	55%	-2°C; -18°C	+28.4°F; -0.4°F
*8+6+12 pozzetti	1,2+5/8	10+8	9+6	12+9	925+502 3.154+1.712	30°C	86°F	55%	-2°C; -18°C	+28.4°F; -0.4°F
*8+8+10 pozzetti	1,2+5/8	10+8	9+6	12+9	925+502 3.154+1.712	30°C	86°F	55%	-2°C; -18°C	+28.4°F; -0.4°F
*12+6+12 pozzetti	1,2+5/8	10+8	9+6	12+9	925+502 3.154+1.712	30°C	86°F	55%	-2°C; -18°C	+28.4°F; -0.4°F
*10+8+12 pozzetti	1,2+5/8	10+8	9+6	12+9	925+502 3.154+1.712	30°C	86°F	55%	-2°C; -18°C	+28.4°F; -0.4°F

\*2 compressori / 2 allacci elettrici \*2 condensing units / 2 electrical connections



		<b>UC</b> CON MOTORE A BORDO WITH BUILT-IN AIR-COOLED CONDENSING UNIT				TENSIONE E FREQUENZA VOLTAGE AND FREQUENCY				
						MONOFASE - V/Ph/Hz <b>230/1/50</b>				
MODELLO MODEL	POTENZA ASSORBITA CURRENT CONSUMPTION		RESA COOLING CAPACITY		CLASSE CLIMATICA CLIMATE CLASS			TEMPERATURA DI ESERCIZIO OPERATING TEMPERATURE		
1 TEMPERATURA 1 TEMPERATURE	monofase 230/1/50		monofase 230/1/50		°C	°F	U.R. R.H.	°C	°F	
	W	A	W/h -30°C	BTU/h -22°F						
L 1250 UC - 4 pozzetti	504	3.25	460	1.570	30°C	86°F	55%	-2°C; -18°C	+28.4°F; -0.4°F	
L 1500 UC - 6 pozzetti	545	3.43	460	1.570	30°C	86°F	55%	-2°C; -18°C	+28.4°F; -0.4°F	
L 1750 UC - 8 pozzetti	746	3.95	615	2.100	30°C	86°F	55%	-2°C; -18°C	+28.4°F; -0.4°F	
L 2000 UC - 10 pozzetti	792	4.15	615	2.100	30°C	86°F	55%	-2°C; -18°C	+28.4°F; -0.4°F	
L 2250 UC - 12 pozzetti	838	4.35	615	2.100	30°C	86°F	55%	-2°C; -18°C	+28.4°F; -0.4°F	

		<b>UC</b> CON MOTORE A BORDO WITH BUILT-IN AIR-COOLED CONDENSING UNIT				TENSIONE E FREQUENZA VOLTAGE AND FREQUENCY				
						MONOFASE - V/Ph/Hz <b>230/1/50</b>				
MODELLO MODEL	POTENZA ASSORBITA CURRENT CONSUMPTION		RESA COOLING CAPACITY		CLASSE CLIMATICA CLIMATE CLASS			TEMPERATURA DI ESERCIZIO OPERATING TEMPERATURE		
2 TEMPERATURE 2 TEMPERATURES	monofase 230/1/50		monofase 230/1/50		°C	°F	U.R. R.H.	°C	°F	
	W	A	W/h -30°C	BTU/h -22°F						
L 2000 UC - 6+4 pozzetti	792	4.15	615	2.100	30°C	86°F	55%	-2°C; -18°C	+28.4°F; -0.4°F	
L 2250 UC - 6+6 pozzetti	838	4.35	615	2.100	30°C	86°F	55%	-2°C; -18°C	+28.4°F; -0.4°F	
L 2250 UC - 4+8 pozzetti	838	4.35	615	2.100	30°C	86°F	55%	-2°C; -18°C	+28.4°F; -0.4°F	
L 2500 UC - 4+10 pozzetti	1037	5.02	925	3.154	30°C	86°F	55%	-2°C; -18°C	+28.4°F; -0.4°F	
L 2500 UC - 6+8 pozzetti	1037	5.02	925	3.154	30°C	86°F	55%	-2°C; -18°C	+28.4°F; -0.4°F	
L 2500 UC - 12+6 pozzetti	1118	5.38	925	3.154	30°C	86°F	55%	-2°C; -18°C	+28.4°F; -0.4°F	
L 2500 UC - 10+8 pozzetti	1118	5.38	925	3.154	30°C	86°F	55%	-2°C; -18°C	+28.4°F; -0.4°F	

		<b>UC</b> CON MOTORE A BORDO WITH BUILT-IN AIR-COOLED CONDENSING UNIT				TENSIONE E FREQUENZA VOLTAGE AND FREQUENCY				
						MONOFASE - V/Ph/Hz <b>230/1/50</b>				
MODELLO MODEL	POTENZA ASSORBITA CURRENT CONSUMPTION		RESA COOLING CAPACITY		CLASSE CLIMATICA CLIMATE CLASS			TEMPERATURA DI ESERCIZIO OPERATING TEMPERATURE		
3 TEMPERATURE 3 TEMPERATURES	monofase 230/1/50		monofase 230/1/50		°C	°F	U.R. R.H.	°C	°F	
	W	A	W/h -30°C	BTU/h -22°F						
* L 3000 UC - 6+4+4 pozzetti	1296	7.40	615+460	2.100+1.569	30°C	86°F	55%	-2°C; -18°C	+28.4°F; -0.4°F	
* L 3500 UC - 6+4+8 pozzetti	1538	8.10	615+615	2.100+2.100	30°C	86°F	55%	-2°C; -18°C	+28.4°F; -0.4°F	
* L 3500 UC - 6+6+6 pozzetti	1383	7.78	615+460	2.100+1.569	30°C	86°F	55%	-2°C; -18°C	+28.4°F; -0.4°F	
* L 3500 UC - 4+10+4 pozzetti	1541	8.27	925+460	3.154+1.569	30°C	86°F	55%	-2°C; -18°C	+28.4°F; -0.4°F	
* L 4000 UC - 6+4+12 pozzetti	1630	8.50	615+615	2.100+2.100	30°C	86°F	55%	-2°C; -18°C	+28.4°F; -0.4°F	
* L 4000 UC - 8+4+10 pozzetti	1630	8.50	615+615	2.100+2.100	30°C	86°F	55%	-2°C; -18°C	+28.4°F; -0.4°F	
* L 4000 UC - 6+6+10 pozzetti	1630	8.50	615+615	2.100+2.100	30°C	86°F	55%	-2°C; -18°C	+28.4°F; -0.4°F	
* L 4000 UC - 8+6+8 pozzetti	1783	8.97	925+615	3.154+2.100	30°C	86°F	55%	-2°C; -18°C	+28.4°F; -0.4°F	

\*2 compressori / 2 allacci elettrici \*2 condensing units / 2 electrical connections

MODELLO MODEL	POTENZA ASSORBITA CURRENT CONSUMPTION				RESA COOLING CAPACITY		CLASSE CLIMATICA CLIMATE CLASS			TEMPERATURA DI ESERCIZIO OPERATING TEMPERATURE	
	monofase 230/1/50		A		monofase 230/1/50		°C	°F	U.R. R.H.	°C	°F
L 750 NUC - 4 pozzetti	629	3.35	615	2.100	30°C	86°F	55%	-2°C; -18°C	+28.4°F; -0.4°F		
L 1000 NUC - 6 pozzetti	670	3.53	615	2.100	30°C	86°F	55%	-2°C; -18°C	+28.4°F; -0.4°F		
L 1250 NUC - 8 pozzetti	720	3.75	615	2.100	30°C	86°F	55%	-2°C; -18°C	+28.4°F; -0.4°F		
L 1500 NUC - 10 pozzetti	862	3.20	925	3.154	30°C	86°F	55%	-2°C; -18°C	+28.4°F; -0.4°F		
L 1750 NUC - 12 pozzetti	908	3.40	925	3.154	30°C	86°F	55%	-2°C; -18°C	+28.4°F; -0.4°F		

MODELLO MODEL	POTENZA ASSORBITA CURRENT CONSUMPTION				RESA COOLING CAPACITY		CLASSE CLIMATICA CLIMATE CLASS			TEMPERATURA DI ESERCIZIO OPERATING TEMPERATURE	
	monofase 230/1/50		A		monofase 230/1/50		°C	°F	U.R. R.H.	°C	°F
L 1500 NUC - 6+4 pozzetti	862	3.20	925	3.154	30°C	86°F	55%	-2°C; -18°C	+28.4°F; -0.4°F		
L 1750 NUC - 6+6 pozzetti	908	3.40	925	3.154	30°C	86°F	55%	-2°C; -18°C	+28.4°F; -0.4°F		
L 1750 NUC - 4+8 pozzetti	908	3.40	925	3.154	30°C	86°F	55%	-2°C; -18°C	+28.4°F; -0.4°F		
L 2000 NUC - 10+4 pozzetti	947	3.57	925	3.154	30°C	86°F	55%	-2°C; -18°C	+28.4°F; -0.4°F		
L 2000 NUC - 8+6 pozzetti	947	3.57	925	3.154	30°C	86°F	55%	-2°C; -18°C	+28.4°F; -0.4°F		
L 2250 NUC - 8+8 pozzetti	988	3.75	925	3.154	30°C	86°F	55%	-2°C; -18°C	+28.4°F; -0.4°F		
L 2250 NUC - 6+10 pozzetti	988	3.75	925	3.154	30°C	86°F	55%	-2°C; -18°C	+28.4°F; -0.4°F		
L 2250 NUC - 12+4 pozzetti	988	3.75	925	3.154	30°C	86°F	55%	-2°C; -18°C	+28.4°F; -0.4°F		
L 2500 NUC - 12+6 pozzetti	1028	3.93	925	3.154	30°C	86°F	55%	-2°C; -18°C	+28.4°F; -0.4°F		
L 2500 NUC - 10+8 pozzetti	1028	3.93	925	3.154	30°C	86°F	55%	-2°C; -18°C	+28.4°F; -0.4°F		

MODELLO MODEL	POTENZA ASSORBITA CURRENT CONSUMPTION				RESA COOLING CAPACITY		CLASSE CLIMATICA CLIMATE CLASS			TEMPERATURA DI ESERCIZIO OPERATING TEMPERATURE	
	monofase 230/1/50		A		monofase 230/1/50		°C	°F	U.R. R.H.	°C	°F
* L 2000 NUC - 6+4+4	1491	7.45	925+615	3.154+2.100	30°C	86°F	55%	-2°C; -18°C	+28.4°F; -0.4°F		
* L 2250 NUC - 6+6+4	1537	7.65	925+615	3.154+2.100	30°C	86°F	55%	-2°C; -18°C	+28.4°F; -0.4°F		
* L 2250 NUC - 4+8+4	1537	7.65	925+615	3.154+2.100	30°C	86°F	55%	-2°C; -18°C	+28.4°F; -0.4°F		
* L 2500 NUC - 6+6+6	1578	7.83	925+615	3.154+2.100	30°C	86°F	55%	-2°C; -18°C	+28.4°F; -0.4°F		
* L 2500 NUC - 6+4+8	1582	7.85	925+615	3.154+2.100	30°C	86°F	55%	-2°C; -18°C	+28.4°F; -0.4°F		
* L 2500 NUC - 10+4+4	1576	7.82	925+615	3.154+2.100	30°C	86°F	55%	-2°C; -18°C	+28.4°F; -0.4°F		
* L 3000 NUC - 10+4+8	1667	7.32	925+615	3.154+2.100	30°C	86°F	55%	-2°C; -18°C	+28.4°F; -0.4°F		
* L 3000 NUC - 6+6+10	1770	6.60	925+925	3.154+3.154	30°C	86°F	55%	-2°C; -18°C	+28.4°F; -0.4°F		
* L 3500 NUC - 10+4+12	1855	6.97	925+925	3.154+3.154	30°C	86°F	55%	-2°C; -18°C	+28.4°F; -0.4°F		
* L 3500 NUC - 8+6+12	1855	6.97	925+925	3.154+3.154	30°C	86°F	55%	-2°C; -18°C	+28.4°F; -0.4°F		
* L 3500 NUC - 8+8+10	1850	6.95	925+925	3.154+3.154	30°C	86°F	55%	-2°C; -18°C	+28.4°F; -0.4°F		
* L 4000 NUC - 12+6+12	1936	7.33	925+925	3.154+3.154	30°C	86°F	55%	-2°C; -18°C	+28.4°F; -0.4°F		
* L 4000 NUC - 10+8+12	1936	7.33	925+925	3.154+3.154	30°C	86°F	55%	-2°C; -18°C	+28.4°F; -0.4°F		

\*2 compressori / 2 allacci elettrici \*2 condensing units / 2 electrical connections



# PANORAMA

**BANCO COMBINATO con e senza riserva**  
**COMBINED COUNTER with 1 and 2 levels of gelato tubs**



CARATTERISTICHE TECNICHE	OPTIONAL	TECHNICAL SPECIFICATIONS	OPTIONALS
<ul style="list-style-type: none"> <li>- vasca monoblocco schiumata in poliuretano iniettato a 40 kg/m3</li> <li>- interno vasca in acciaio inox 18/10 AISI 304</li> <li>- piletta di scarico vasca con tappo di chiusura per facilitare le operazioni di sbrinamento e di pulizia</li> <li>- 1 + 2 livelli di carapine H 250 mm</li> <li>- sistema anti-rotazione delle carapine</li> <li>- chiusura ermetica con ante in vetro pirolitico, temperato e riscaldato</li> <li>- illuminazione LED</li> <li>- refrigerazione ventilata</li> <li>- pannello comandi elettronico</li> <li>- sbrinamento manuale con arresto dell'impianto</li> </ul>	<ul style="list-style-type: none"> <li>- carapine con sistema anti-rotazione</li> <li>- lavaporizzatore</li> <li>- motore remoto</li> </ul>	<ul style="list-style-type: none"> <li>- monobloc foam tank insulated with injected polyurethane (40 kg/m3)</li> <li>- tank interior in 18/10 AISI 304 stainless steel</li> <li>- tank drains with plug to facilitate defrosting and cleaning operations</li> <li>- 1 + 2 levels of 250 mm / 9.84" high gelato tubs</li> <li>- exclusive tubs anti-rotation system</li> <li>- tempered and heated airtight glass closure system</li> <li>- LED lighting</li> <li>- ventilated refrigeration system</li> <li>- electronic control panel</li> <li>- manual defrost function with system stoppage</li> </ul>	<ul style="list-style-type: none"> <li>- tubs with anti-rotation system</li> <li>- scoop washer</li> <li>- remote condensing unit</li> </ul>

## SEZIONI SECTION VIEWS

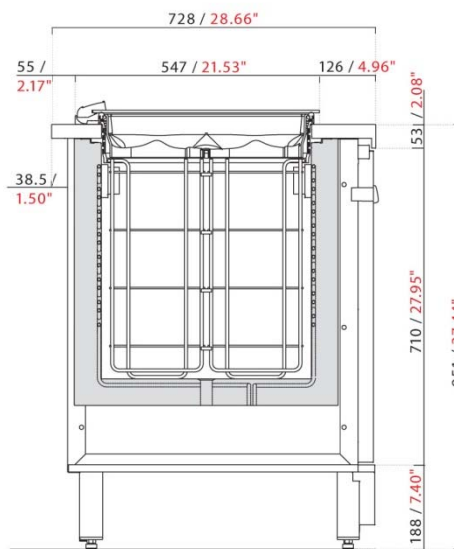
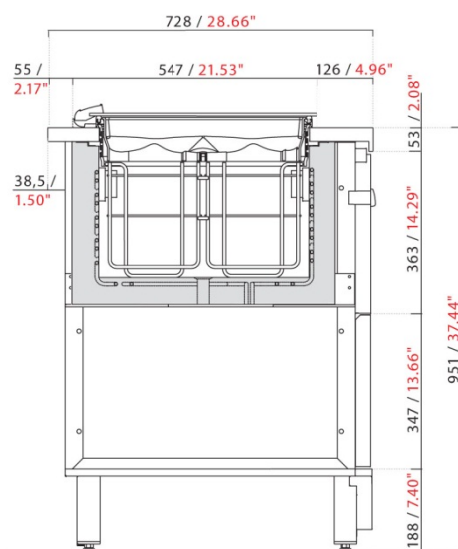

### BANCO PANORAMA SENZA RISERVA

PANORAMA pozzetti counter with 1 level of gelato tubs

### BANCO PANORAMA CON RISERVA

PANORAMA pozzetti counter with 2 levels of gelato tubs

## DIMENSIONI, PESO E IMBALLO DIMENSIONS, WEIGHT AND PACKAGING

MODELLO MODEL	LUNGHEZZA con 2 fianchi LENGTH with 2 end panels		PROFONDITÀ DEPTH		PESO WEIGHT		DIMENSIONE IMBALLO PACKAGING DIMENSIONS		PESO con imballo CRATED WEIGHT	
	mm	in	mm	in	kg	lb	mm	in	kg	lb
L 1500	1560	61.42"	728	28.66"	90	198	1624x911xH1367	63.9"x35.9"xH53.8"	141	311
L 1750	1810	71.26"	728	28.66"	105	231	2124x911xH1367	83.6"x35.9"xH53.8"	169	373
L 2000	2060	81.10"	728	28.66"	120	265	2124x911xH1367	83.6"x35.9"xH53.8"	184	406
L 2250	2310	90.94"	728	28.66"	135	298	2624x911xH1367	103.3"x35.9"xH53.8"	213	470
L 2500	2560	100.79"	728	28.66"	150	331	2624x911xH1367	103.3"x35.9"xH53.8"	228	503
L 3000	3060	120.47"	728	28.66"	180	397	3124x911xH1367	123"x35.9"xH53.8"	272	600
L 3500	3560	140.16"	728	28.66"	210	463	3724x1074xH1367	146.6"x42.3"xH53.8"	336	741
L 4000	4060	159.84"	728	28.66"	240	529	4224x1074xH1367	166.3"x42.3"xH53.8"	382	842

## 2 TEMPERATURE 2 TEMPERATURES

MODULI UC = con motore a bordo UC units = with built-in air-cooled condensing unit

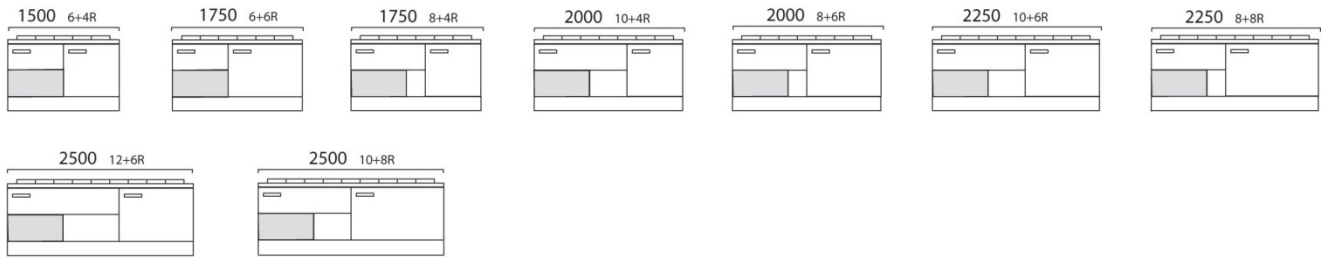

MODULI NUC = con motore remoto NUC units = with remote condensing unit

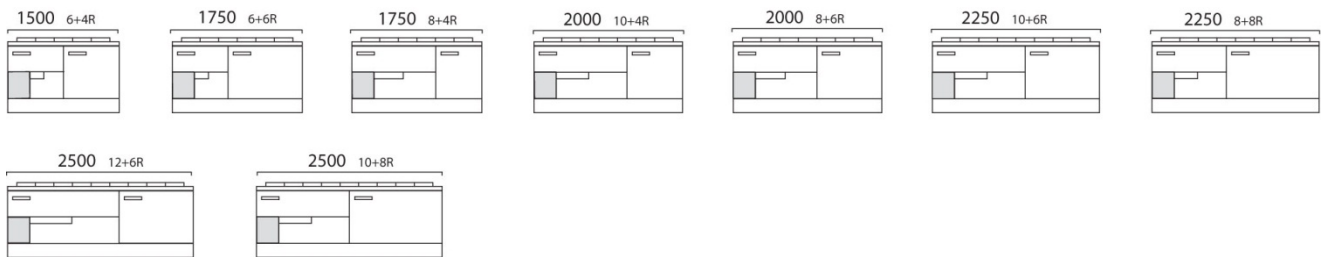

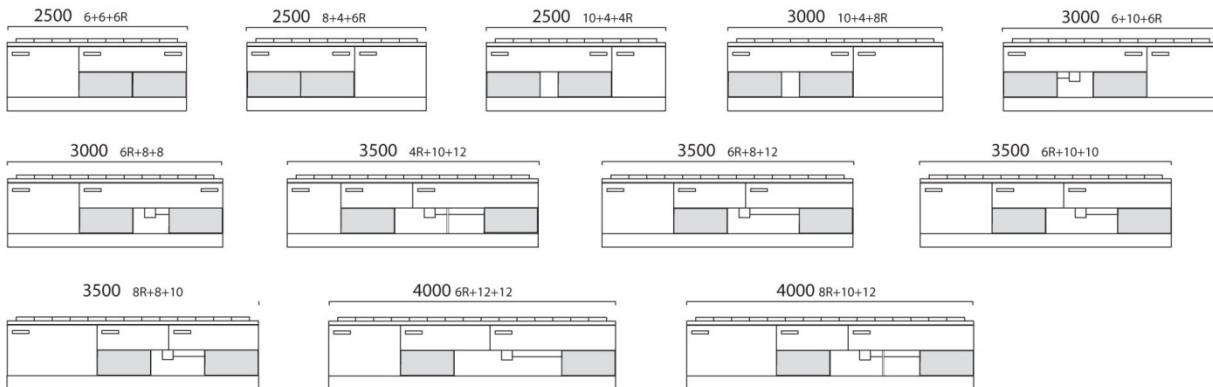

## 3 TEMPERATURE 3 TEMPERATURES

MODULI UC = con motore a bordo UC units = with built-in air-cooled condensing unit

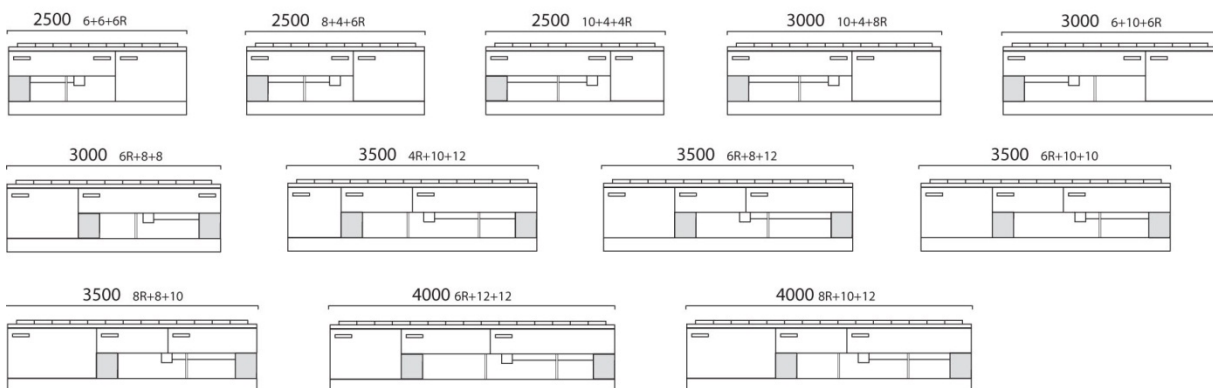

MODULI NUC = con motore remoto NUC units = with remote condensing unit



			UC = con motore a bordo UC = with built-in air-cooled condensing unit  NUC = con motore remoto entro 10 metri NUC = with condensing unit within 20 meters				TENSIONE E FREQUENZA VOLTAGE AND FREQUENCY  V/Ph/Hz <b>208-220/1/60</b>				
MODELLO MODEL	POTENZA COMP. HP	BREAKE R SIZE	MCA	MOP	RESA CAPACITY		CLASSE CLIMATICA CLIMATE CLASS			TEMPERATURA DI ESERCIZIO OPERATING TEMPERATURE	
<b>2 TEMPERATURE 2 TEMPERATURES</b>	HP	<b>A</b>	<b>A</b>	<b>A</b>	W/h -30°C	BTU/h -22°F	°C	°F	U.R. R.H.	°C	°F
6+4R pozzetti	5/8	8	6	9	502	1.712	30°C	86°F	55%	-2°C; -18°C	+28.4°F; -0.4°F
6+6R pozzetti	5/8	8	6	9	502	1.712	30°C	86°F	55%	-2°C; -18°C	+28.4°F; -0.4°F
8+4R pozzetti	5/8	8	6	9	502	1.712	30°C	86°F	55%	-2°C; -18°C	+28.4°F; -0.4°F
10+4R pozzetti	1,2	10	8	12	925	3.154	30°C	86°F	55%	-2°C; -18°C	+28.4°F; -0.4°F
8+6R pozzetti	1,2	10	8	12	925	3.154	30°C	86°F	55%	-2°C; -18°C	+28.4°F; -0.4°F
10+6R pozzetti	1,2	10	9	12	925	3.154	30°C	86°F	55%	-2°C; -18°C	+28.4°F; -0.4°F
8+8R pozzetti	1,2	10	9	12	925	3.154	30°C	86°F	55%	-2°C; -18°C	+28.4°F; -0.4°F
10+8R pozzetti	1,2	10	9	12	925	3.154	30°C	86°F	55%	-2°C; -18°C	+28.4°F; -0.4°F
12+6R pozzetti	1,2	10	9	12	925	3.154	30°C	86°F	55%	-2°C; -18°C	+28.4°F; -0.4°F

			UC = con motore a bordo UC = with built-in air-cooled condensing unit  NUC = con motore remoto entro 10 metri NUC = with condensing unit within 20 meters				TENSIONE E FREQUENZA VOLTAGE AND FREQUENCY  V/Ph/Hz <b>208-220/1/60</b>				
MODELLO MODEL	POTENZA COMP. HP	BREAKE R SIZE	MCA	MOP	RESA CAPACITY		CLASSE CLIMATICA CLIMATE CLASS			TEMPERATURA DI ESERCIZIO OPERATING TEMPERATURE	
<b>3 TEMPERATURE 3 TEMPERATURES</b>	HP	<b>A</b>	<b>A</b>	<b>A</b>	W/h -30°C	BTU/h -22°F	°C	°F	U.R. R.H.	°C	°F
*6R+6+6	5/8+1/2	8+8	6+7	9+10	502+460	1.712+1.570	30°C	86°F	55%	-2°C; -18°C	+28.4°F; -0.4°F
*8+4+6R	5/8+1/2	8+8	6+7	9+10	502+460	1.712+1.570	30°C	86°F	55%	-2°C; -18°C	+28.4°F; -0.4°F
*10+4+4R	1,2+1/2	10+8	8+7	12+10	925+460	3.154+1.570	30°C	86°F	55%	-2°C; -18°C	+28.4°F; -0.4°F
*10+4+8R	1,2+5/8	10+8	8+6	12+8	925+502	3.154+1.712	30°C	86°F	55%	-2°C; -18°C	+28.4°F; -0.4°F
*6+10+6R	1,2+1/2	10+8	9+6	12+9	925+502	3.154+1.712	30°C	86°F	55%	-2°C; -18°C	+28.4°F; -0.4°F
*6R+8+8	1,2+5/8	10+8	8+6	12+8	925+502	3.154+1.712	30°C	86°F	55%	-2°C; -18°C	+28.4°F; -0.4°F
*4R+10+12	1,2+5/8	10+8	8+6	12+9	925+502	3.154+1.712	30°C	86°F	55%	-2°C; -18°C	+28.4°F; -0.4°F
*6R+8+12	1,2+5/8	10+8	8+6	12+9	925+502	3.154+1.712	30°C	86°F	55%	-2°C; -18°C	+28.4°F; -0.4°F
*6R+10+10	1,2+5/8	10+8	9+6	12+9	925+502	3.154+1.712	30°C	86°F	55%	-2°C; -18°C	+28.4°F; -0.4°F
*8R+8+10	1,2+5/8	10+8	9+6	12+9	925+502	3.154+1.712	30°C	86°F	55%	-2°C; -18°C	+28.4°F; -0.4°F
*6R+12+12	1,2+5/8	10+8	9+6	12+9	925+502	3.154+1.712	30°C	86°F	55%	-2°C; -18°C	+28.4°F; -0.4°F
*8R+10+12	1,2+5/8	10+8	9+6	12+9	925+502	3.154+1.712	30°C	86°F	55%	-2°C; -18°C	+28.4°F; -0.4°F

\*2 compressori / 2 allacci elettrici \*2 condensing units / 2 electrical connections

DATI TECNICI CE con motore a bordo CE TECHNICAL SPECIFICATIONS with condensing unit on board

			UC CON MOTORE A BORDO WITH BUILT-IN AIR-COOLED CONDENSING UNIT				TENSIONE E FREQUENZA VOLTAGE AND FREQUENCY MONOFASE - V/Ph/Hz <b>230/1/50</b>				
MODELLO MODEL	POTENZA ASSORBITA CURRENT CONSUMPTION		RESA COOLING CAPACITY		CLASSE CLIMATICA CLIMATE CLASS			TEMPERATURA DI ESERCIZIO OPERATING TEMPERATURE			
<b>2 TEMPERATURE 2 TEMPERATURES</b>	monofase 230/1/50		monofase 230/1/50		°C	°F	U.R. R.H.	°C	°F		
	W	A	W/h -30°C	BTU/h -22°F							
L 1500 UC - 6+4R pozzetti	792	4.15	615	2.100	30°C	86°F	55%	-2°C; -18°C	+28.4°F; -0.4°F		
L 1750 UC - 6+6R pozzetti	838	4.35	615	2.100	30°C	86°F	55%	-2°C; -18°C	+28.4°F; -0.4°F		
L 1750 UC - 8+4R pozzetti	838	4.35	615	2.100	30°C	86°F	55%	-2°C; -18°C	+28.4°F; -0.4°F		
L 2000 UC - 10+4R pozzetti	1037	5.02	925	3.154	30°C	86°F	55%	-2°C; -18°C	+28.4°F; -0.4°F		
L 2000 UC - 8+6R pozzetti	1037	5.02	925	3.154	30°C	86°F	55%	-2°C; -18°C	+28.4°F; -0.4°F		
L 2250 UC - 10+6R pozzetti	1078	5.20	925	3.154	30°C	86°F	55%	-2°C; -18°C	+28.4°F; -0.4°F		
L 2250 UC - 8+8R pozzetti	1078	5.20	925	3.154	30°C	86°F	55%	-2°C; -18°C	+28.4°F; -0.4°F		
L 2500 UC - 12+6R pozzetti	1118	5.38	925	3.154	30°C	86°F	55%	-2°C; -18°C	+28.4°F; -0.4°F		
L 2500 UC - 10+8R pozzetti	1118	5.38	925	3.154	30°C	86°F	55%	-2°C; -18°C	+28.4°F; -0.4°F		



UC  
CON MOTORE A BORDO  
WITH BUILT-IN AIR-COOLED CONDENSING UNIT

TENSIONE E FREQUENZA VOLTAGE AND FREQUENCY

MONOFASE - V/Ph/Hz **230/1/50**

MODELLO MODEL	POTENZA ASSORBITA CURRENT CONSUMPTION		RESA COOLING CAPACITY		CLASSE CLIMATICA CLIMATE CLASS			TEMPERATURA DI ESERCIZIO OPERATING TEMPERATURE	
	monofase 230/1/50		monofase 230/1/50		°C	°F	U.R. R.H.	°C	°F
3 TEMPERATURE 3 TEMPERATURES	W	A	W/h -30°C	BTU/h -22°F					
* L 2500 UC - 6R+6+6	1383	7.78	615+460	2.100+1.570	30°C	86°F	55%	-2°C; -18°C	+28.4°F; -0.4°F
* L 2500 UC - 8+4+6R	1383	7.78	615+460	2.100+1.570	30°C	86°F	55%	-2°C; -18°C	+28.4°F; -0.4°F
* L 2500 UC - 10+4+4R	1541	8.27	925+460	3.154+1.570	30°C	86°F	55%	-2°C; -18°C	+28.4°F; -0.4°F
* L 3000 UC - 10+4+8R	1783	8.97	925+615	3.154+2.100	30°C	86°F	55%	-2°C; -18°C	+28.4°F; -0.4°F
* L 3000 UC - 6+10+6R	1623	8.63	925+460	3.154+1.570	30°C	86°F	55%	-2°C; -18°C	+28.4°F; -0.4°F
* L 3000 UC - 6R+8+8	1783	8.97	925+615	3.154+2.100	30°C	86°F	55%	-2°C; -18°C	+28.4°F; -0.4°F
* L 3500 UC - 4R+10+12	1875	9.37	925+615	3.154+2.100	30°C	86°F	55%	-2°C; -18°C	+28.4°F; -0.4°F
* L 3500 UC - 6R+8+12	1875	9.37	925+615	3.154+2.100	30°C	86°F	55%	-2°C; -18°C	+28.4°F; -0.4°F
* L 3500 UC - 6R+10+10	1870	9.35	925+615	3.154+2.100	30°C	86°F	55%	-2°C; -18°C	+28.4°F; -0.4°F
* L 3500 UC - 8R+8+10	1870	9.35	925+615	3.154+2.100	30°C	86°F	55%	-2°C; -18°C	+28.4°F; -0.4°F
* L 4000 UC - 6R+12+12	1956	9.73	925+615	3.154+2.100	30°C	86°F	55%	-2°C; -18°C	+28.4°F; -0.4°F
* L 4000 UC - 8R+10+12	1956	9.73	925+615	3.154+2.100	30°C	86°F	55%	-2°C; -18°C	+28.4°F; -0.4°F

\*2 compressori / 2 allacci elettrici \*2 condensing units / 2 electrical connections

DATI TECNICI CE con motore remoto CE TECHNICAL SPECIFICATIONS with remote condensing unit



CON MOTORE ENTRO 20 METRI  
WITH CONDENSING UNIT WITHIN 20 METERS

TENSIONE E FREQUENZA VOLTAGE AND FREQUENCY

MONOFASE - V/Ph/Hz **230/1/50**

MODELLO MODEL	POTENZA ASSORBITA CURRENT CONSUMPTION		RESA COOLING CAPACITY		CLASSE CLIMATICA CLIMATE CLASS			TEMPERATURA DI ESERCIZIO OPERATING TEMPERATURE	
	monofase 230/1/50		monofase 230/1/50		°C	°F	U.R. R.H.	°C	°F
2 TEMPERATURE 2 TEMPERATURES	W	A	W/h -30°C	BTU/h -22°F					
L 1500 NUC - 6+4R pozzetti	862	3.20	925	3.154	30°C	86°F	55%	-2°C; -18°C	+28.4°F; -0.4°F
L 1750 NUC - 6+6R pozzetti	908	3.40	925	3.154	30°C	86°F	55%	-2°C; -18°C	+28.4°F; -0.4°F
L 1750 NUC - 8+4R pozzetti	908	3.40	925	3.154	30°C	86°F	55%	-2°C; -18°C	+28.4°F; -0.4°F
L 2000 NUC - 10+4R pozzetti	947	3.57	925	3.154	30°C	86°F	55%	-2°C; -18°C	+28.4°F; -0.4°F
L 2000 NUC - 8+6R pozzetti	947	3.57	925	3.154	30°C	86°F	55%	-2°C; -18°C	+28.4°F; -0.4°F
L 2250 NUC - 8+8R pozzetti	988	3.75	925	3.154	30°C	86°F	55%	-2°C; -18°C	+28.4°F; -0.4°F
L 2250 NUC - 10+6R pozzetti	988	3.75	925	3.154	30°C	86°F	55%	-2°C; -18°C	+28.4°F; -0.4°F
L 2500 NUC - 12+6R pozzetti	1028	3.93	925	3.154	30°C	86°F	55%	-2°C; -18°C	+28.4°F; -0.4°F
L 2500 NUC - 10+8R pozzetti	1028	3.93	925	3.154	30°C	86°F	55%	-2°C; -18°C	+28.4°F; -0.4°F



CON MOTORE ENTRO 20 METRI  
WITH CONDENSING UNIT WITHIN 20 METERS

TENSIONE E FREQUENZA VOLTAGE AND FREQUENCY

MONOFASE - V/Ph/Hz **230/1/50**

MODELLO MODEL	POTENZA ASSORBITA CURRENT CONSUMPTION		RESA COOLING CAPACITY		CLASSE CLIMATICA CLIMATE CLASS			TEMPERATURA DI ESERCIZIO OPERATING TEMPERATURE	
	monofase 230/1/50		monofase 230/1/50		°C	°F	U.R. R.H.	°C	°F
3 TEMPERATURE 3 TEMPERATURES	W	A	W/h -30°C	BTU/h -22°F					
* L 2500 NUC - 6+6+6R	1578	7.83	925+615	3.154+2.100	30°C	86°F	55%	-2°C; -18°C	+28.4°F; -0.4°F
* L 2500 NUC - 8+4+6R	1578	7.83	925+615	3.154+2.100	30°C	86°F	55%	-2°C; -18°C	+28.4°F; -0.4°F
* L 2500 NUC - 10+4+4R	1576	7.82	925+615	3.154+2.100	30°C	86°F	55%	-2°C; -18°C	+28.4°F; -0.4°F
* L 3000 NUC - 10+4+8R	1667	7.32	925+615	3.154+2.100	30°C	86°F	55%	-2°C; -18°C	+28.4°F; -0.4°F
* L 3000 NUC - 6+10+6R	1658	7.28	925+615	3.154+2.100	30°C	86°F	55%	-2°C; -18°C	+28.4°F; -0.4°F
* L 3000 NUC - 6R+8+8	1667	7.32	925+615	3.154+2.100	30°C	86°F	55%	-2°C; -18°C	+28.4°F; -0.4°F
* L 3500 NUC - 4R+10+12	1855	6.97	925+925	3.154+3.154	30°C	86°F	55%	-2°C; -18°C	+28.4°F; -0.4°F
* L 3500 NUC - 6R+8+12	1855	6.97	925+925	3.154+3.154	30°C	86°F	55%	-2°C; -18°C	+28.4°F; -0.4°F
* L 3500 NUC - 6R+10+10	1850	6.95	925+925	3.154+3.154	30°C	86°F	55%	-2°C; -18°C	+28.4°F; -0.4°F
* L 3500 NUC - 8R+8+10	1850	6.95	925+925	3.154+3.154	30°C	86°F	55%	-2°C; -18°C	+28.4°F; -0.4°F
* L 4000 NUC - 6R+12+12	1936	7.33	925+925	3.154+3.154	30°C	86°F	55%	-2°C; -18°C	+28.4°F; -0.4°F
* L 4000 NUC - 8R+10+12	1936	7.33	925+925	3.154+3.154	30°C	86°F	55%	-2°C; -18°C	+28.4°F; -0.4°F

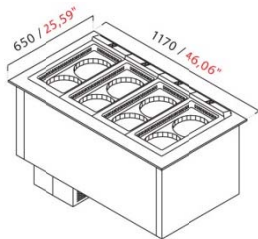

# PANORAMA

## VASCA da incasso senza riserva / 1 level built-in pozzetti TANK



CARATTERISTICHE TECNICHE	OPTIONAL	TECHNICAL SPECIFICATIONS	OPTIONALS
<ul style="list-style-type: none"> <li>- vasca monoblocco schiumata in poliuretano iniettato a 40 kg/m<sup>3</sup></li> <li>- 1 livello di carapine H 250 mm</li> <li>- piano da incasso in acciaio inox finitura Scotch-brite</li> <li>- chiusura ermetica con ante in vetro piro litico, temperato e riscaldato</li> <li>- illuminazione LED</li> <li>- sistema anti-rotazione delle carapine</li> <li>- vasca interna in acciaio inox con piletta di scarico dotata di tappo di chiusura</li> <li>- refrigerazione ventilata</li> <li>- pannello comandi elettronico</li> <li>- sbrinamento manuale con arresto dell'impianto</li> </ul>	<ul style="list-style-type: none"> <li>- carapine con sistema anti-rotazione</li> </ul>	<ul style="list-style-type: none"> <li>- monobloc foam tank insulated with injected polyurethane (40 kg/m<sup>3</sup>)</li> <li>- 1 level of 250 mm / 9.84" high gelato tubs</li> <li>- stainless steel top with Scotch-Brite finish, which fits into the hole prepared on the counter top</li> <li>- tempered and heated airtight glass closure system</li> <li>- LED lighting</li> <li>- exclusive tubs anti-rotation system</li> <li>- inner basin in stainless steel with drain</li> <li>- ventilated refrigeration system</li> <li>- electronic control panel</li> <li>- manual defrost function with system stoppage</li> </ul>	<ul style="list-style-type: none"> <li>- tubs with anti-rotation system</li> </ul>

### SEZIONE SECTION VIEW

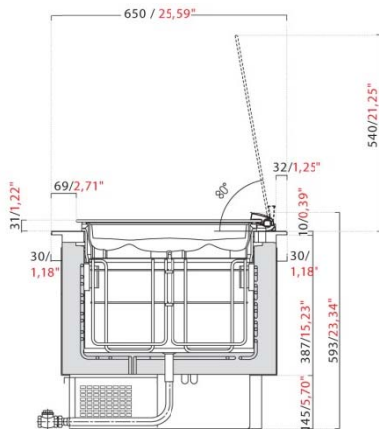

VASCA PANORAMA INCASSO SENZA RISERVA 1 LEVEL BUILT-IN PANORAMA TANK

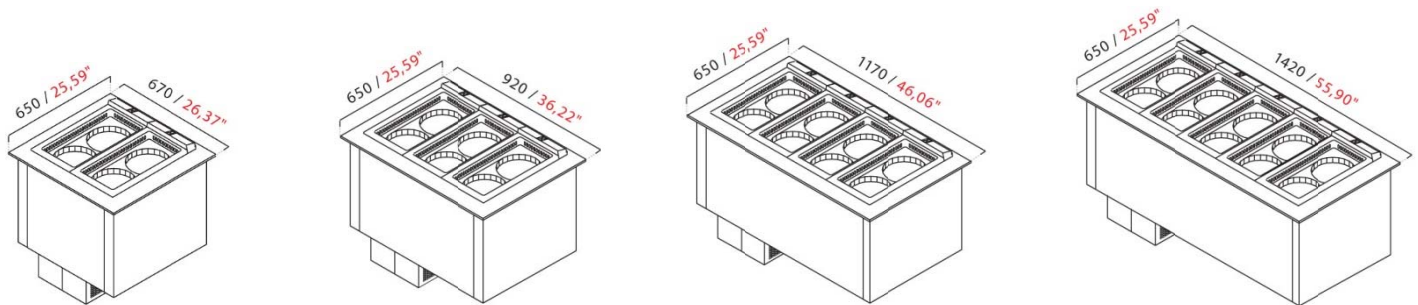

**4 pozzetti / 4 pozzetti holes**  
4 carapine - 7 litri cad.  
4 tubs - 7 liters each

**6 pozzetti / 6 pozzetti holes**  
6 carapine - 7 litri cad.  
6 tubs - 7 liters each

**8 pozzetti / 8 pozzetti holes**  
8 carapine - 7 litri cad.  
8 tubs - 7 liters each

**10 pozzetti / 10 pozzetti holes**  
10 carapine - 7 litri cad.  
10 tubs - 7 liters each

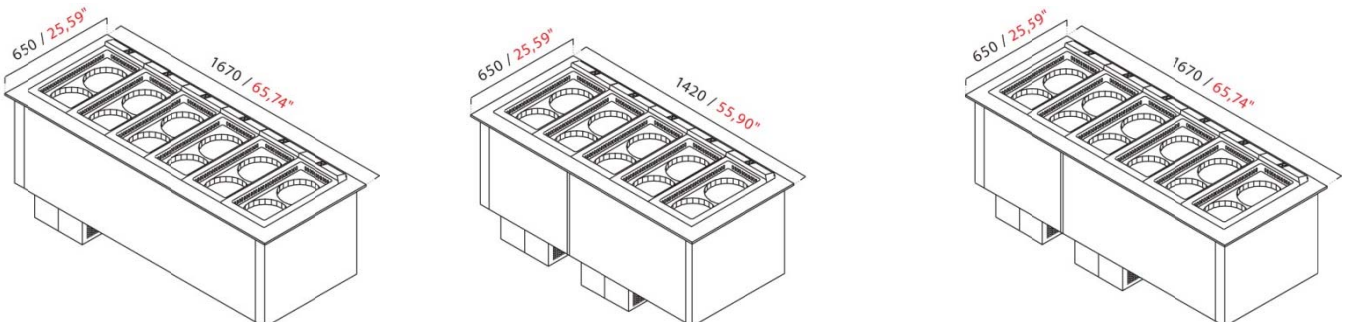

**12 pozzetti / 12 pozzetti holes**  
12 carapine - 7 litri cad.  
12 tubs - 7 liters each

**\*TD 4+6 pozzetti / \*TD 4+6 pozzetti holes**  
10 carapine - 7 litri cad.  
10 tubs - 7 liters each

**\*TD 4+8 pozzetti / \*TD 4+8 pozzetti holes**  
12 carapine - 7 litri cad.  
12 tubs - 7 liters each

\*TD= temperatura differenziata / dual temperature

\*TD= temperatura differenziata / dual temperature

DIMENSIONI, PESO E IMBALLO DIMENSIONS, WEIGHT AND PACKAGING

MODELLO MODEL	LUNGHEZZA LENGTH		PROFONDITÀ DEPTH		PESO WEIGHT		DIMENSIONE IMBALLO PACKAGING DIMENSIONS		PESO con imballo CRATED WEIGHT	
	mm	in	mm	in	kg	lb	mm	in	kg	lb
4 pozzetti	670	26.37"	650	25.59"	46	101	1624x911xH832	63.9"x35.9"xH32.8"	97	214
6 pozzetti	920	36.22"	650	25.59"	64	141	1624x911xH832	63.9"x35.9"xH32.8"	115	254
8 pozzetti	1170	46.06"	650	25.59"	82	181	2124x911xH832	83.6"x35.9"xH32.8"	146	322
10 pozzetti	1420	55.90"	650	25.59"	100	220	2124x911xH832	83.6"x35.9"xH32.8"	164	362
12 pozzetti	1670	65.74"	650	25.59"	118	260	2624x911xH832	103.3"x35.9"xH32.8"	196	432
4+6 pozzetti	1420	55.90"	650	25.59"	100	220	2124x911xH832	83.6"x35.9"xH32.8"	164	362
4+8 pozzetti	1670	65.74"	650	25.59"	118	260	2624x911xH832	103.3"x35.9"xH32.8"	196	432

DATI TECNICI TECHNICAL SPECIFICATIONS

 3065103 ETL* - NSF 7 - UL STD 471 - CAN/CSA C22.2 STD n. 120 Intertek Intertek		CON MOTORE A BORDO WITH BUILT-IN AIR-COOLED CONDENSING UNIT  CON MOTORE REMOTO ENTRO 10 METRI WITH CONDENSING UNIT WITHIN 10 METERS					TENSIONE E FREQUENZA VOLTAGE AND FREQUENCY  V/Ph/Hz <b>208-220/1/60</b>				
MODELLO MODEL	POTENZA COMP. HP	BREAKER SIZE	MCA	MOP	RESA CAPACITY	CLASSE CLIMATICA CLIMATE CLASS			TEMPERATURA DI ESERCIZIO OPERATING TEMPERATURE		
	HP	A	A	A	W/h -30°C	BTU/h -22°F	°C	°F	U.R. R.H.	°C	°F
4 pozzetti	1/2	8	7	10	460	1.569	30°C	86°F	55%	-2°C; -18°C	+28.4°F; -0.4°F
6 pozzetti	1/2	8	7	10	460	1.569	30°C	86°F	55%	-2°C; -18°C	+28.4°F; -0.4°F
8 pozzetti	5/8	8	6	8	502	1.712	30°C	86°F	55%	-2°C; -18°C	+28.4°F; -0.4°F
10 pozzetti	5/8	8	6	9	502	1.712	30°C	86°F	55%	-2°C; -18°C	+28.4°F; -0.4°F
12 pozzetti	5/8	8	6	9	502	1.712	30°C	86°F	55%	-2°C; -18°C	+28.4°F; -0.4°F
4+6 pozzetti	5/8	8	6	9	502	1.712	30°C	86°F	55%	-2°C; -18°C	+28.4°F; -0.4°F
4+8 pozzetti	5/8	8	6	9	502	1.712	30°C	86°F	55%	-2°C; -18°C	+28.4°F; -0.4°F

 UC CON MOTORE A BORDO WITH BUILT-IN AIR-COOLED CONDENSING UNIT		TENSIONE E FREQUENZA VOLTAGE AND FREQUENCY  MONOFASE - V/Ph/Hz <b>230/1/50</b>	
---	--	--	--

MODELLO MODEL	POTENZA ASSORBITA CURRENT CONSUMPTION		RESA COOLING CAPACITY		CLASSE CLIMATICA CLIMATE CLASS			TEMPERATURA DI ESERCIZIO OPERATING TEMPERATURE	
	monofase 230/1/50		monofase 230/1/50		°C	°F	U.R. R.H.	°C	°F
	W	A	W/h -30°C	BTU/h -22°F					
4 pozzetti	504	3.25	460	1.570	30°C	86°F	55%	-2°C; -18°C	+28.4°F; -0.4°F
6 pozzetti	545	3.43	460	1.570	30°C	86°F	55%	-2°C; -18°C	+28.4°F; -0.4°F
8 pozzetti	746	3.95	615	2.100	30°C	86°F	55%	-2°C; -18°C	+28.4°F; -0.4°F
10 pozzetti	792	4.15	615	2.100	30°C	86°F	55%	-2°C; -18°C	+28.4°F; -0.4°F
12 pozzetti	838	4.35	615	2.100	30°C	86°F	55%	-2°C; -18°C	+28.4°F; -0.4°F
4+6 pozzetti	792	4.15	615	2.100	30°C	86°F	55%	-2°C; -18°C	+28.4°F; -0.4°F
4+8 pozzetti	832	4.33	615	2.100	30°C	86°F	55%	-2°C; -18°C	+28.4°F; -0.4°F

 CON MOTORE REMOTO ENTRO 20 METRI WITH CONDENSING UNIT WITHIN 20 METERS		TENSIONE E FREQUENZA / VOLTAGE AND FREQUENCY  MONOFASE - V/Ph/Hz <b>230/1/50</b>	
--	--	--	--

MODELLO MODEL	POTENZA ASSORBITA CURRENT CONSUMPTION		RESA COOLING CAPACITY		CLASSE CLIMATICA CLIMATE CLASS			TEMPERATURA DI ESERCIZIO OPERATING TEMPERATURE	
	monofase 230/1/50		monofase 230/1/50		°C	°F	U.R. R.H.	°C	°F
	W	A	W/h -30°C	BTU/h -22°F					
4 pozzetti	629	3.35	615	2.100	30°C	86°F	55%	-2°C; -18°C	+28.4°F; -0.4°F
6 pozzetti	670	3.53	615	2.100	30°C	86°F	55%	-2°C; -18°C	+28.4°F; -0.4°F
8 pozzetti	720	3.75	615	2.100	30°C	86°F	55%	-2°C; -18°C	+28.4°F; -0.4°F
10 pozzetti	862	4.10	925	3.154	30°C	86°F	55%	-2°C; -18°C	+28.4°F; -0.4°F
12 pozzetti	908	4.30	925	3.154	30°C	86°F	55%	-2°C; -18°C	+28.4°F; -0.4°F
4+6 pozzetti	862	4.10	925	3.154	30°C	86°F	55%	-2°C; -18°C	+28.4°F; -0.4°F
4+8 pozzetti	908	4.30	925	3.154	30°C	86°F	55%	-2°C; -18°C	+28.4°F; -0.4°F





# PANORAMA

## VASCA da incasso con riserva / 2 levels built-in pozzetti TANK



CARATTERISTICHE TECNICHE	OPTIONAL	TECHNICAL SPECIFICATIONS	OPTIONALS
<ul style="list-style-type: none"> <li>- vasca monoblocco schiumata in poliuretano iniettato a 40 kg/m3</li> <li>- 2 livelli di carapine H 250 mm</li> <li>- piano da incasso in acciaio inox finitura Scotch-brite</li> <li>- chiusura ermetica con ante in vetro piro litico, temperato e riscaldato</li> <li>- illuminazione LED</li> <li>- sistema anti-rotazione delle carapine</li> <li>- vasca interna in acciaio inox con piletta di scarico dotata di tappo di chiusura</li> <li>- refrigerazione ventilata</li> <li>- pannello comandi elettronico</li> <li>- sbrinamento manuale con arresto dell'impianto</li> </ul>	<ul style="list-style-type: none"> <li>- carapine con sistema anti-rotazione</li> </ul>	<ul style="list-style-type: none"> <li>- monobloc foam tank insulated with injected polyurethane (40 kg/m3)</li> <li>- 2 levels of 250 mm / 9.84" high gelato tubs</li> <li>- stainless steel top with Scotch-Brite finish, which fits into the hole prepared on the counter top</li> <li>- tempered and heated airtight glass closure system</li> <li>- LED lighting</li> <li>- exclusive tubs anti-rotation system</li> <li>- inner basin in stainless steel with drain</li> <li>- ventilated refrigeration system</li> <li>- electronic control panel</li> <li>- manual defrost function with system stoppage</li> </ul>	<ul style="list-style-type: none"> <li>- tubs with anti-rotation system</li> </ul>

### SEZIONE SECTION VIEW

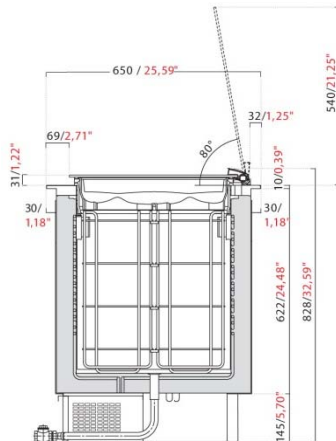

VASCA PANORAMA INCASSO CON RISERVA

2 LEVELS BUILT-IN PANORAMA TANK

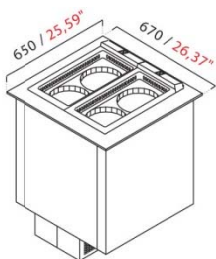

**4 pozzetti / 4 pozzetti holes**  
8 carapine - 7 litri cad.  
8 tubs - 7 liters each

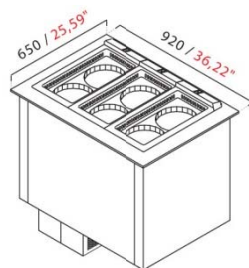

**6 pozzetti / 6 pozzetti holes**  
12 carapine - 7 litri cad.  
12 tubs - 7 liters each

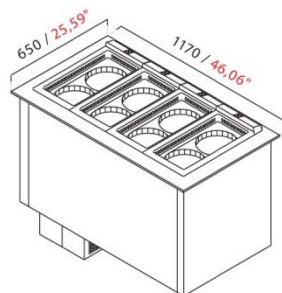

**8 pozzetti / 8 pozzetti holes**  
16 carapine - 7 litri cad.  
16 tubs - 7 liters each

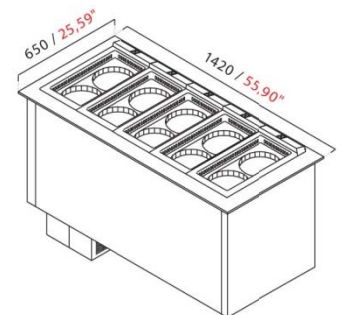

**10 pozzetti / 10 pozzetti holes**  
20 carapine - 7 litri cad.  
20 tubs - 7 liters each

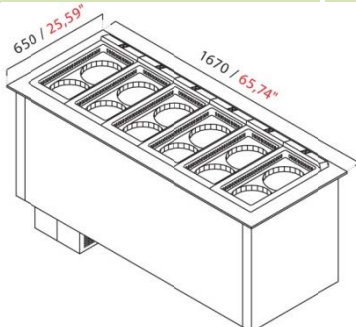

**12 pozzetti / 12 pozzetti holes**  
24 carapine - 7 litri cad.  
24 tubs - 7 liters each

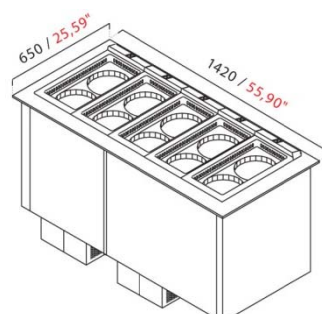

**\*TD 4+6 pozzetti / TD 4+6 pozzetti holes**  
8+12 carapine - 7 litri cad.  
8+12 tubs - 7 liters each  
\*TD= temperatura differenziata / dual temperature

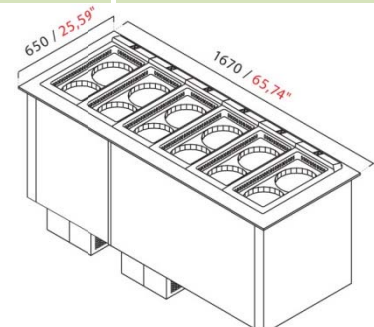

**\*TD 4+8 pozzetti / TD 4+8 pozzetti holes**  
8+16 carapine - 7 litri cad.  
8+16 tubs - 7 liters each  
\*TD= temperatura differenziata / dual temperature

DIMENSIONI, PESO E IMBALLO DIMENSIONS, WEIGHT AND PACKAGING

MODELLO MODEL	LUNGHEZZA LENGTH		PROFONDITÀ DEPTH		PESO WEIGHT		DIMENSIONE IMBALLO PACKAGING DIMENSIONS		PESO con imballo CRATED WEIGHT	
	mm	in	mm	in	kg	lb	mm	in	kg	lb
4 pozzetti	670	26.37"	650	25.59"	52	115	1624x911xH1067	63.9"x35.9"xH42"	103	227
6 pozzetti	920	36.22"	650	25.59"	71	157	1624x911xH1067	63.9"x35.9"xH42"	122	269
8 pozzetti	1170	46.06"	650	25.59"	90	198	2124x911xH1067	83.6"x35.9"xH42"	154	340
10 pozzetti	1420	55.90"	650	25.59"	109	240	2124x911xH1067	83.6"x35.9"xH42"	173	381
12 pozzetti	1670	65.74"	650	25.59"	128	282	2624x911xH1067	103.3"x35.9"xH42"	206	454
4+6 pozzetti	1420	55.90"	650	25.59"	109	240	2124x911xH1067	83.6"x35.9"xH42"	173	381
4+8 pozzetti	1670	65.74"	650	25.59"	128	282	2624x911xH1067	103.3"x35.9"xH42"	206	454

DATI TECNICI TECHNICAL SPECIFICATIONS

 3065103 ETL* - NSF 7 - UL STD 471 US - CAN/CSA C22.2 STD n. 120 Intertek Intertek		CON MOTORE A BORDO WITH BUILT-IN AIR-COOLED CONDENSING UNIT  CON MOTORE REMOTO ENTRO 10 METRI WITH CONDENSING UNIT WITHIN 10 METERS					TENSIONE E FREQUENZA VOLTAGE AND FREQUENCY  V/Ph/Hz <b>208-220/1/60</b>				
MODELLO MODEL	POTENZA COMP. HP	BREAKER SIZE	MCA	MOP	RESA CAPACITY	CLASSE CLIMATICA CLIMATE CLASS			TEMPERATURA DI ESERCIZIO OPERATING TEMPERATURE		
	HP	A	A	A	W/h -30°C	BTU/h -22°F	°C	°F	U.R. R.H.	°C	°F
4 pozzetti	1/2	8	7	10	460	1.569	30°C	86°F	55%	-2°C; -18°C	+28.4°F; -0.4°F
6 pozzetti	1/2	8	7	10	460	1.569	30°C	86°F	55%	-2°C; -18°C	+28.4°F; -0.4°F
8 pozzetti	5/8	8	6	8	502	1.712	30°C	86°F	55%	-2°C; -18°C	+28.4°F; -0.4°F
10 pozzetti	5/8	8	6	9	502	1.712	30°C	86°F	55%	-2°C; -18°C	+28.4°F; -0.4°F
12 pozzetti	5/8	8	6	9	502	1.712	30°C	86°F	55%	-2°C; -18°C	+28.4°F; -0.4°F
4+6 pozzetti	5/8	8	6	9	502	1.712	30°C	86°F	55%	-2°C; -18°C	+28.4°F; -0.4°F
4+8 pozzetti	5/8	8	6	9	502	1.712	30°C	86°F	55%	-2°C; -18°C	+28.4°F; -0.4°F

 UC CON MOTORE A BORDO WITH BUILT-IN AIR-COOLED CONDENSING UNIT		TENSIONE E FREQUENZA VOLTAGE AND FREQUENCY  MONOFASE - V/Ph/Hz <b>230/1/50</b>	
---	--	--	--

MODELLO MODEL	POTENZA ASSORBITA CURRENT CONSUMPTION		RESA COOLING CAPACITY		CLASSE CLIMATICA CLIMATE CLASS			TEMPERATURA DI ESERCIZIO OPERATING TEMPERATURE	
	monofase 230/1/50		monofase 230/1/50		°C	°F	U.R. R.H.	°C	°F
	W	A	W/h -30°C	BTU/h -22°F					
4 pozzetti	504	3.25	460	1.570	30°C	86°F	55%	-2°C; -18°C	+28.4°F; -0.4°F
6 pozzetti	545	3.43	460	1.570	30°C	86°F	55%	-2°C; -18°C	+28.4°F; -0.4°F
8 pozzetti	746	3.95	615	2.100	30°C	86°F	55%	-2°C; -18°C	+28.4°F; -0.4°F
10 pozzetti	792	4.15	615	2.100	30°C	86°F	55%	-2°C; -18°C	+28.4°F; -0.4°F
12 pozzetti	838	4.35	615	2.100	30°C	86°F	55%	-2°C; -18°C	+28.4°F; -0.4°F
4+6 pozzetti	792	4.15	615	2.100	30°C	86°F	55%	-2°C; -18°C	+28.4°F; -0.4°F
4+8 pozzetti	838	4.35	615	2.100	30°C	86°F	55%	-2°C; -18°C	+28.4°F; -0.4°F

 CON MOTORE REMOTO ENTRO 20 METRI WITH CONDENSING UNIT WITHIN 20 METERS		TENSIONE E FREQUENZA / VOLTAGE AND FREQUENCY  MONOFASE - V/Ph/Hz <b>230/1/50</b>	
--	--	--	--

MODELLO MODEL	POTENZA ASSORBITA CURRENT CONSUMPTION		RESA COOLING CAPACITY		CLASSE CLIMATICA CLIMATE CLASS			TEMPERATURA DI ESERCIZIO OPERATING TEMPERATURE	
	monofase 230/1/50		monofase 230/1/50		°C	°F	U.R. R.H.	°C	°F
	W	A	W/h -30°C	BTU/h -22°F					
4 pozzetti	629	3.35	615	2.100	30°C	86°F	55%	-2°C; -18°C	+28.4°F; -0.4°F
6 pozzetti	670	3.53	615	2.100	30°C	86°F	55%	-2°C; -18°C	+28.4°F; -0.4°F
8 pozzetti	720	3.75	615	2.100	30°C	86°F	55%	-2°C; -18°C	+28.4°F; -0.4°F
10 pozzetti	862	4.10	925	3.158	30°C	86°F	55%	-2°C; -18°C	+28.4°F; -0.4°F
12 pozzetti	908	4.30	925	3.158	30°C	86°F	55%	-2°C; -18°C	+28.4°F; -0.4°F
4+6 pozzetti	862	4.10	925	3.158	30°C	86°F	55%	-2°C; -18°C	+28.4°F; -0.4°F
4+8 pozzetti	908	4.30	925	3.158	30°C	86°F	55%	-2°C; -18°C	+28.4°F; -0.4°F